

TM 5-4330-217-12

DEPARTMENT OF THE ARMY TECHNICAL MANUAL

TECHNICAL MANUAL

OPERATOR AND ORGANIZATIONAL

MAINTENANCE MANUAL

INCLUDING REPAIR PARTS AND SPECIAL TOOLS LIST

FILTER-SEPARATOR, LIQUID FUEL; 100 GPM;

FRAME MOUNTED (KEENE CORP. MODEL

844-5-V100AL)

FSN 4330-491-4957

This copy is a reprint which includes current pages
from changes 1, 3, 4, 5, and 6.

HEADQUARTERS,

DEPARTMENT

OF

THE

ARMY

APRIL 1973

WARNING

FLAMMABLE FLUIDS are processed through this equipment.

DEATH

or severe burns may result if personnel fail to observe safety precautions. The combustible characteristics of the products handled make it imperative that sparks, open flames, and electrical discharges be avoided.

CAUSTIC CHEMICALS

are contained in some of the products that are filtered by the unit.

DEATH

or severe burns may result if personnel fail to observe safety precautions. Fuel resistant rubber gloves must be worn when replacing elements.

DO NOT REMOVE filter-separator head until all pressure has been released.

Spills must be avoided and cleaned up immediately when they occur. Drainage tubs or other suitable containers must be placed as needed under hose connections, dispensers, and similar locations to collect leakage.

Rules prohibiting smoking and open flames in the area must be established and strictly enforced. Adequate **NO SMOKING** signs must be prominently posted.

CHANGE }
NO. 7 }

HEADQUARTERS
DEPARTMENT OF THE ARMY
WASHINGTON, D. C., 30 December 1994

**Operator's and Organizational Maintenance Manual
(Including Repair Parts and Special Tools List)**

**FILTER SEPARATOR, LIQUID FUEL; 100 GPM:
FRAME-MOUNTED (KEENE CORP. MODEL 844-5-V-100AL)
(VELCON FILTERS, INCL. MODEL V-1520-ANZ)
(BETA SYSTEMS, MODEL FS100-VM)**

NSN 4330-00-491-4957

TM 5-4330-217-12, 5 April 1973, is changed as follows:

Title Is changed as shown above.

Page 1-1. Paragraph 1-1 is superseded as follows:

1-1. Scope

This manual is for your use in operating and maintaining the 100 GPM filter-separators (Keene Corp. Model 844-5-V-100AL, Velcon Filters, Inc. Model V-1520-ANZ and Beta Systems, Inc. Model FS100-VM).

Page 1-1. Paragraph 1-2. Change TM38-750 to DA PAM 738-50, The Army Maintenance Management System (TAMMS).

Page 1-1. Paragraph 1-3 is superseded as follows:

1-3. Reporting of Errors

You can help improve this manual. If you find any mistakes, or if you know of a way to improve the procedures, please let us know. Mail your letter, DA Form 2028 (Recommended Changes to Publications and Blank Forms) direct to: Commander, U.S. Army Aviation and Troop Command, ATTN: AMSAT-I-MP, 4300 Goodfellow Blvd., St. Louis, MO 63120-1798. A reply will be furnished directly to you.

Page 1-1. Paragraph 1-5a is superseded as follows:

a. *General Description.* The filter-separators are designed to filter and separate particles of contamination and water from light petroleum fuels. It is capable of handling fuel at a rate of 100 gallons per minute (GPM). It consists of a vessel with a removable cover, five replaceable filter elements and canisters, a water-level sight gage, a manual water drain valve, a manual air vent valve, and inlet and outlet couplings. The Model 844-5-V-100AL has a differential pressure indicator and the Models V-1520-ANZ and FS-100VM have a differential pressure gage.

Page 1-3. Figure 1-2 (Sheet 1 of 2) and (Sheet 2 of 2) is superseded as follows:

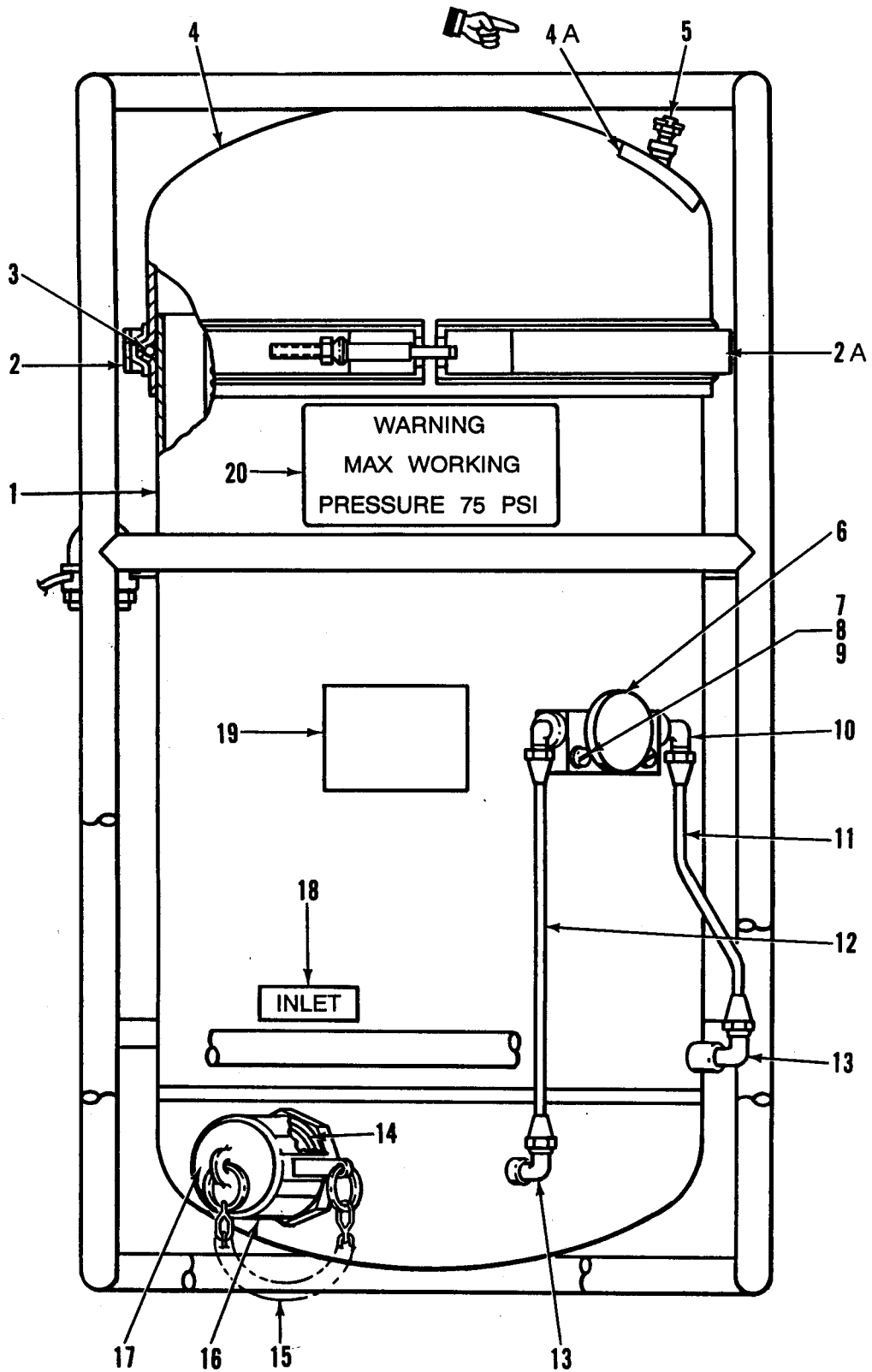

Figure 1-2. Liquid Filter Separator (Sheet 1 of 2).

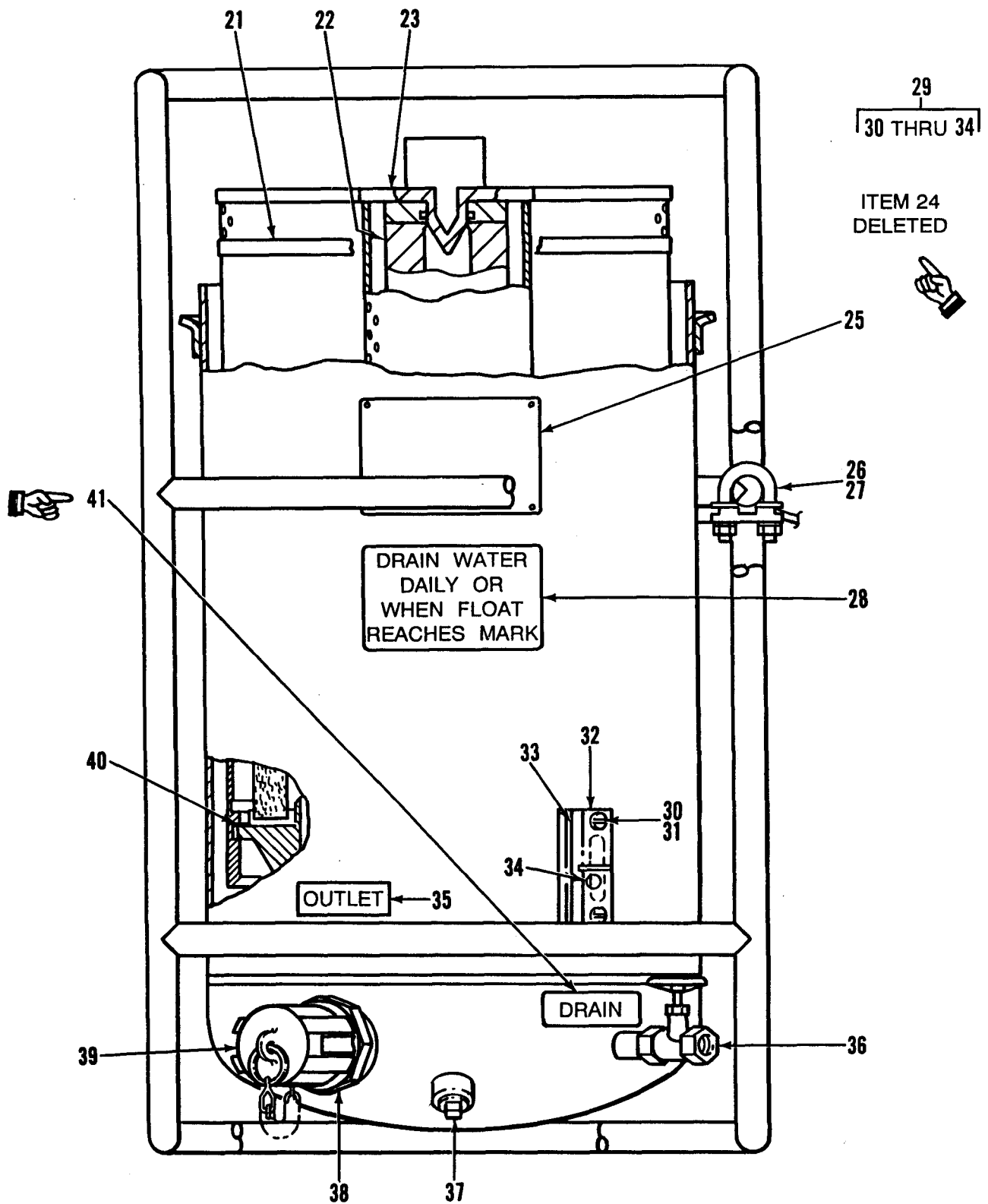

Figure 1-2. Liquid Filter Separator (Sheet 2 of 2).

Page 1-5. Paragraph 1-6 is superseded as follows:

1-6. Differences in Models. The differences in models are that the Model 844-5-V-100AL has a pop-up type differential pressure indicator and Models V-1520-ANZ and FS-100VM have a differential pressure indicating gage.

Page 1-5. Paragraph 1-7b (1.2) is added as follows:

- (1.2) *Identification.*
- | | |
|---------------------------|--------------------|
| Manufacturer | Beta Systems, Inc. |
| Model Number | FS-100VM |
| Federal Stock No. | 4330-00-491-4957 |
| Contract No | DAAK01-93-C-0106 |
| Specification No. | 52556C |

Page 1-5. Paragraph 1-7b (5.1). Change heading to read:

- (5.1) *Differential pressure indicator (Models V-1520-ANZ and FS-100VM).*

Page 2-1. Paragraph 2-2b (5) is superseded as follows:

(5) Check differential indicator periodically. Change filter elements (para 3-5) immediately if the red button on the indicator is in a raised position (Model 844-5-V-100AL) or the gage readings are in any portion of the red band (Models V-1520-ANZ and FS-100VM).

Page 2-2. Paragraph 2-4a (3), add as follows:

(3) For Model V-1520-ANZ and FS-100VM filter-separators, check the pressure differential gage periodically to be sure the pressure reading is below the red band on the gage.

Page 2-2. Paragraph 2-4b (5), add as follows:

(5) For Model V-1520-ANZ and FS-100VM filter-separators, check the pressure differential gage periodically to be sure the pressure reading is below the red band on the gage.

Page 2-2. Paragraph 2-4c (4), add as follows:

(4) For Model V-1520-ANZ and FS-100VM filter-separators, check the pressure differential gage periodically to be sure the pressure reading is below the red band on the gage.

Page 2-2. Paragraph 2-4d (3), add as follows:

(3) For Model V-1520-ANZ and FS-100VM filter-separators, check the pressure differential gage periodically to be sure the pressure reading is below the red band on the gage.

Page 2-2. Paragraph 2-4e (3), add as follows:

(3) For Model V-1520-ANZ and FS-100VM filter-separators, check the pressure differential gage periodically to be sure the pressure reading is below the red band on the gage.

Page 4-5. Table 4-2, Item 1, "Malfunction" column add:

"YELLOW BAND READING ON DIFFERENTIAL PRESSURE GAGE (MODELS V-1520-ANZ AND FS-100VM)."

Item 2, "Malfunction" column add:

"RED BAND READING ON DIFFERENTIAL PRESSURE GAGE (MODELS V-1520-ANZ AND FS-100VM)"

Page 4-6. Paragraph 4-13b, in new sentence (Change 1) add "FS-100-VM" after V-1520-ANZ.

Page 4-6. Paragraph 4-15a (4). Change to read:

(4) *Model V-1520-ANZ or FS-100VM filter-separator gage.*

Page 4-8. Paragraph 4-15c (4). Change to read:

(4) *Model V-1520-ANZ or FS-100VM filter-separators.*

Page 4-8. Paragraph 4-16a is superseded as follows:

a. The differential pressure indicator (Model 844-5-V-100AL) or gage (Models V-1520-ANZ and FS-100VM) may be tested by supplying an equal-gauged pressure of 50 PSI to each of the ports, then increasing the pressure at the high pressure inlet port until the buttons "pop up" on the indicator, or to move the needle on the gage. The difference between the two pressure readings should be 20 PSI±15% for the yellow button (gage band) and 35 PSI±15% for the red button (gage band). Replace the differential pressure indicator (gage) if it is inoperative or not within tolerance.

Appendix D, SectionII. Maintenance Allocation Chart. Add group 05 as follows:

(1) Group No.	(2) Assembly Group	(3) Maintenance Functions											(4) Tools & Equip.	(5) Remark	
		A	B	C	D	E	F	G	H	I	J	K			
05	ADAPTER ASSEMBLY	C							O	O					
		0.1							0.5	0.8					
	Sampling Probe	C							O						
		0.1							0.2						

Page C-4, Group 01, Line 2. In column (3), delete part number "13217E5356", and add part number "13220E0991".

Page C-4, Group 02, Line 16. In column (3), delete part number "WWV54" and MFR code "(81348)", and add part number "MSS-SP-80" and MFR code "(59646)".

Page C-5, Group 03, Line 4. In column (3), delete part number "FF-S-92" and MFR code "(81348)", and add part number "MS35206-285" and MFR code "(96906)".

Page C-5, Group 04, Line 6. In column (3), delete part number "13217E5366", and add part number "13219E9753".

Page C-5, Group 04, Line 18. In column (3), delete part number "13216E2718", and add part number "13216E2768".

Page C-5, Group 04, Line 23. In column (3), add "Plate, Data". In column (4), add unit of measure "EA". In column (5), add quantity "1". In column (7) (a), add figure number "1-2". In column (7)(b), add item number "4A".

Page C-5, Group 04, Line 24. In column (3), add part number "13230E3381" and MFR code "(97403)".

TM 5-4330-217-12
C7

Page C-5, Group 04, Line 25. In column (3), add "Plate, Data". In column (4), add unit of measure "EA". In column (5), add quantity "1". In column (7) (a), add figure number "1-2". In column (7) (b), add item number "41".

Page C-5, Group 04, Line 26. In column (3), add part number "13230E3382" and MFR code "(97403)".

By Order of the Secretary of the Army:

Official:

MILTON H. HAMILTON

*Administrative Assistant to the
Secretary of the Army*

07755

GORDON R. SULLIVAN
*General, United States Army
Chief of Staff*

DISTRIBUTION:

To be distributed in accordance with DA Form 12-25-E, block no. 0781, requirements for
TM 5-4330-217-12.

CHANGE }
NO. 6 }

HEADQUARTERS
DEPARTMENT OF THE ARMY
WASHINGTON, DC, 9 MAY 1988

**Operator's and Organizational Maintenance Manual
(Including Repair Parts and Special Tools List)**

**FILTER SEPARATOR, LIQUID FUEL; 100 GPM:
FRAME-MOUNTED (KEENE CORP. MODEL 844-5-V-100AL)
(VELCON FILTERS, INCL. MODEL V-1520-ANZ)
(BETA SYSTEMS, MODEL FS100-VM)**

NSN 4330-00-491-4957

TM 5-4330-217-12, 5 April 1973, is changed as follows:

Page C-4, Group 02, Line 3. In column (2), delete FSN "4730-196-9585". In column (3), delete "Connector, Male (19237)".

Page C-4, Group 02, Line 3. In column (3), add "Elbow".

Page C-4, Group 02, Line 4. In column (3), delete part number "AN816-5-4D" and MFR code "(88044)".

Page C-4, Group 02, Line 4. In column (3), add part number "MS20822-5D" and MFR code "(96906)".

Page C-4, Group 02, Line 5. In column (5), change quantity "2" to quantity "1". In column (7)(b) delete "11".

Page C-4, Group 02, Line 21. In column (3), add "Tube Assembly". In column (5), add quantity "1". In column (7)(a), add figure number "1-2". In column (7)(b), add item number "11".

Page C-4, Group 02, Line 22. In column (3), add part number "13217E5365-4" and MFR code "(97403)".

Page C-5, Group 03, Line 1. In column (2), delete FSN "6685-451-3274". In column (3), delete "(27N22)".

Page C-5, Group 03, Line 2. In column (3), delete part number "13218E8895-2", and add part number "13219E9749".

Page C-5, Group 03, Line 3. In column (2), delete FSN "5305-071-2089". In column (3), delete "(27N48)".

Page C-5, Group 03, Line 4. In column (3), delete part number "MS51957-89" and MFR code "(96906)", and add part number "FF-S-92" and MFR code "(81348)".

Page C-5, Group 04, Line 9. Delete this line in its entirety from columns (1) thru (7).

Page C-5, Group 04, Line 10. In column (3), delete part number "MS21318-21" and MFR code "(96906)".

Page C-5, Group 04, Line 15. In column (2), delete FSN "5975-878-3791". In column (3), delete "(49M27)".

Page C-5, Group 04, Line 16. In column (3), delete part number "MILR11461" and MFR code "(81349)", and add part number "W-R-550" and MFR code "(81348)".

TM 5-4330-217-12
C 6

By Order of the Secretary of the Army:

CARL E. VUONO
General, United States Army
Chief of Staff

Official:

R. L. DILWORTH
Brigadier General, United States Army
The Adjutant General

DISTRIBUTION:

To be distributed in accordance with DA Form 12-25A, Operator and Unit Maintenance requirements for Filter-Separator, Liquid Fuel, Frame Mounted, 100 GPM (844-5-V-100AL)(V-1520-ANZ).

☆ U.S. GOVERNMENT PRINTING OFFICE: 1988-554-169/87029

CHANGE }
No. 5 }

HEADQUARTERS
DEPARTMENT OF THE ARMY
WASHINGTON, D.C., 21 October 1987

Operator's and Organizational Maintenance Manual
(Including Repair Parts and Special Tools List)

FILTER SEPARATOR, LIQUID FUEL; 100 GPM:
FRAME-MOUNTED (KEENE CORP. MODEL 844-5-V-100AL)
(VELCON FILTERS, INCL. MODEL V-1520-ANZ)
NSN 4330-00-491-4957

TM 5-4330-217-12, 5 April 1973, is changed as follows:

Page C-4, figure 1-2, item 36 should be changed to read 4820-00-554-8713, VALVE, GATE, ½ INCH 49M15 (08181)

Page 3/4 (of change 4), figure C-1, item 1 should be changed to read PA0ZZ, 4930-01-017-3639, ADAPTER.

Page 3/4 (of change 4), figure C-1, item 8 should be changed to read PA0ZZ, 4930-01-017-3638, PROBE ASSEMBLY.

By Order of the Secretary of the Army:

CARL E. VUONO
General, United States Army
Chief of Staff

OFFICIAL:

R. L. DILWORTH
Brigadier General, United States Army
The Adjutant General

DISTRIBUTION:

To be distributed in accordance with DA Form 12-25A, Operator and Unit Maintenance requirements for Filter-Separator, Liquid Fuel, Frame Mounted, 100 GPM (844-5-V-100AL) (V-1520-ANZ).

CHANGE }
No. 4 }

HEADQUARTERS
DEPARTMENT OF THE ARMY
WASHINGTON, D.C., 7 February 1985

Operator's and Organizational Maintenance Manual
(Including Repair Parts and Special Tools List)

FILTER SEPARATOR, LIQUID FUEL; 100 GPM:
FRAME-MOUNTED (KEENE CORP. MODEL 844-5-V-100AL)
(VELCON FILTERS, INCL. MODEL V-1520-ANZ)
NSN 4330-00-491-4957

TM 5-4330-217-12, 5 April 1973, is changed as follows:

Table of Contents page. Add to Group "05, Detector Kit Adapter," under page column, add "C-5.1."

Page 1-1, paragraph 1-2. Change TM 38-750 to read "DA Pam 738-750."

Page 1-1, paragraph 1-3. Lines 5 through 9 are changed to read "Commander, U.S. Army Troop Support Command, ATTN: AMSTR-MPS, 4300 Goodfellow Boulevard, St. Louis, MO 63120-1798."

Page 3-2. Table 3-1, Preventive Maintenance Checks and Services is replaced with "Table 3-1. Operator/Crew Preventive Maintenance Checks and Services."

Page A-1. Reference A-6, TM 38-750 should be changed to read "DA Pam 738-750."

Page C-5. Add page "C-5.1" after page C-5.

By Order of the Secretary of the Army:

JOHN A. WICKHAM, JR.
General, United States Army
Chief of Staff

Official:

DONALD J. DELANDRO
Brigadier General, United States Army
The Adjutant General

DISTRIBUTION:

To be distributed in accordance with DA Form 12-25A, Operator and Organizational Maintenance requirements for Petroleum Distribution.

Table 3-1. Operator/Crew Preventive Maintenance Checks and Services

NOTE

Within designated interval, these checks are to be performed in the order listed.

B-Before

D-During

A-After

Item No.	Interval			Item To be Inspected	Procedures Check for and have repaired or adjusted as necessary	Equipment is Not Ready/ Available if:
	B	D	A			
1	●			Filter Separator	<p>Make the following walk around checks:</p> <p>a. Check for leaks. Check for loose or missing bolts in cover assembly. Check frame for breaks.</p> <p>b. Check that all valves operate freely.</p> <p>c. Check that gaskets are in place. Check that gaskets are not damaged or leaking.</p> <p>d. Check that ground wire is not broken and is connected properly.</p>	
2		●		Water Level Sight Gage	Check for breaks, damage, and leaks. Ensure ball floats freely.	
3		●		Differential Pressure Gage	Check that pressure indication is below red band on the gage. If yellow, change elements after operation.	
4			●	Dust Caps & Plugs	Ensure dust caps and plugs are installed after operation. If not installed, flush discharge hose before operation.	

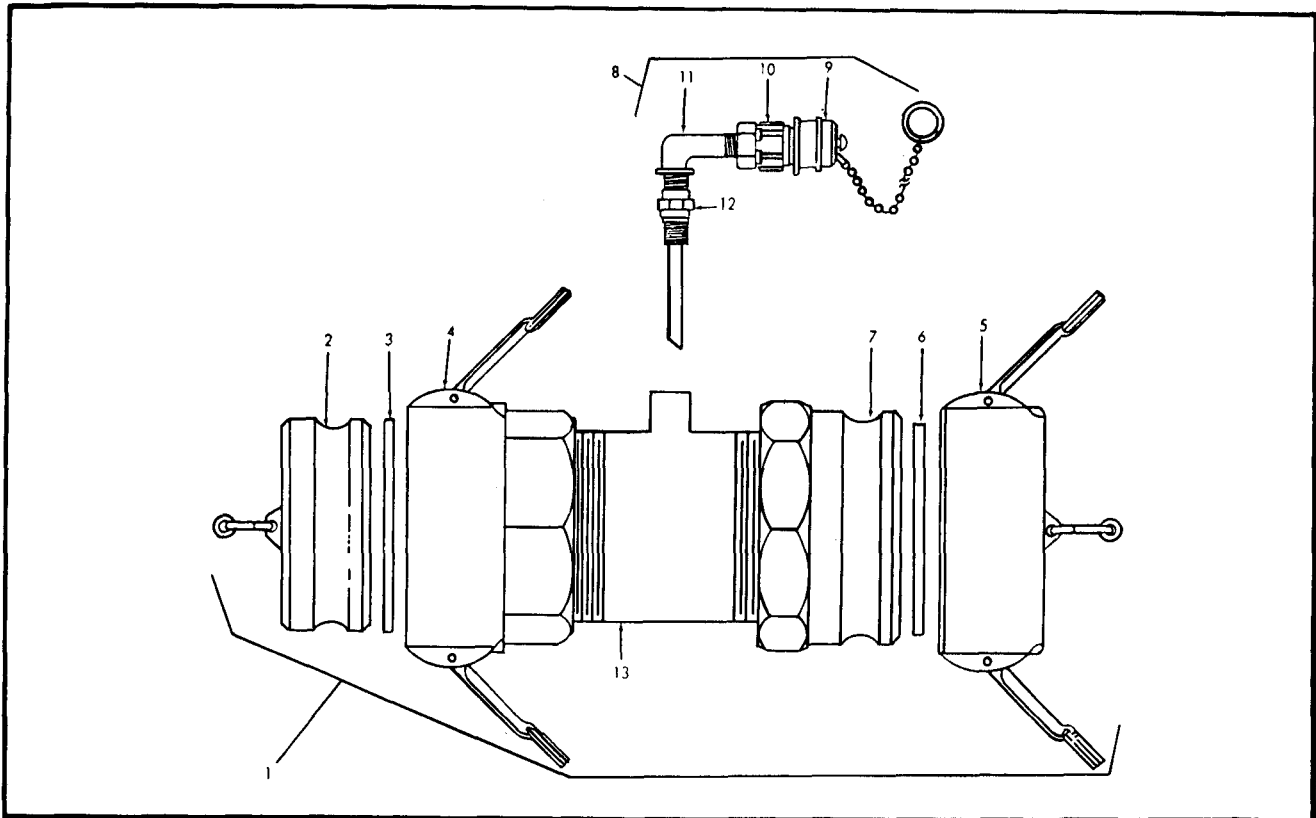

(1) SMR CODE	(2) FEDERAL STOCK NUMBER	(3) DESCRIPTION	(4) UNIT OF MEAS	(5) QTY INC IN UNIT	(6) 15-DAY ORGANIZATIONAL MAINTENANCE ALW				(7) ILLUS- TRATION	
					(a)	(b)	(c)	(d)	(a)	(b)
					1-5	6-20	21-50	51-100	FIG. NO.	ITEM NO.
		GROUP 05 - DETECTOR KIT ADAPTER								
PO		ADAPTER, WATER DETECTOR KIT (97403) 13220E9406-1	EA	1	*	*	*	*	C-1	1
X20		PLUG, DUST ADAPTER (96906) MS27029-11	EA	1	*	*	*	*	C-1	2
PO	5310-00-612-2414	GASKET, DUST PLUG (96906) MS27030-6	EA	1	*	*	*	*	C-1	3
PO		COUPLING HALF, FEMALE (96906) MS27024-11	EA	1	*	*	*	*	C-1	4
X20		CAP, DUST: ADAPTER (96906) MS27028-1 1	EA	1	*	*	*	*	C-1	5
PO	5310-00-612-2414	GASKET, COUPLING (96906) MS27030-6	EA	1	*	*	*	*	C-1	6
X20		COUPLING HALF, MALE (96906) MS27020-1 1	EA	1	*	*	*	*	C-1	7
PO		PROBE ASSEMBLY, WATER DETECTOR KIT (96906) 13220E991 4-1	EA	1	*	*	*	*	C-1	8
PO		PLUG, DUST: PROBE (32218) AMPE 4 (W/BC)	EA	1	*	*	*	*	C-1	9
X20		COUPLER, QUICK DISCONNECT: FEMALE (32218) AVEC 4-4F	EA	1	*	*	*	*	C-1	10
X20		ELBOW, STREET 1/4 NPT AL (32218) SE-4	EA	1	*	*	*	*	C-1	11
X20		PROBE, SAMPLING (32218) GTP 144-1 1/2	EA	1	*	*	*	*	C-1	12
X20		NIPPLE, PIPE: 2 IN NPT X 4 IN LG MIL-P-25995 (81349) SCH40-AL-6061-T6	EA	1	*	*	*	*	C-1	13

Figure C-1 Adapter, water detector kit.

CHANGE
NO. 3

HEADQUARTERS
DEPARTMENT OF THE ARMY
WASHINGTON, D C, 3 March 1978

**Operator's and Organizational Maintenance Manual
(Including Repair Parts and Special Tools List)**

**FILTER SEPARATOR, LIQUID FUEL; 100 GPM:
FRAME-MOUNTED (KEENE CORP. MODEL 844-5-V-100AL)
(VELCON FILTERS, INCL. MODEL V-1520-ANZ)
NSN 4330-00-491-4957**

TM 5-4330-217-12, 5 April 1973, is changed as follows:

NOTE

Throughout this manual where the words "Federal Stock Number (FSN)" appear, change to read "National Stock Number (NSN)". Add after the federal supply classification (FSC) two zeros "00", or "01" whichever applies, then the remaining numbers. EXAMPLE: FSN 4330-491-4957 becomes NSN 4330-00-491-4957.

Table of Contents Page. Appendixes on this page are changed as follows:

Appendix A References
Appendix B Components of End Item List

Appendix C Additional Authorization List
Appendix D Maintenance Allocation Chart
Appendix E Repair Parts and Special Tools List
Appendix F Expendable Supplies and Materials List (Not Applicable)

Page 1-2, Legend for Fig. 1-1. After item 2, add item 2A, "Coupler 'v' retainer".

Page 1-3. Figure 1-2 (Sheet 1 of 2) is superseded as follows:

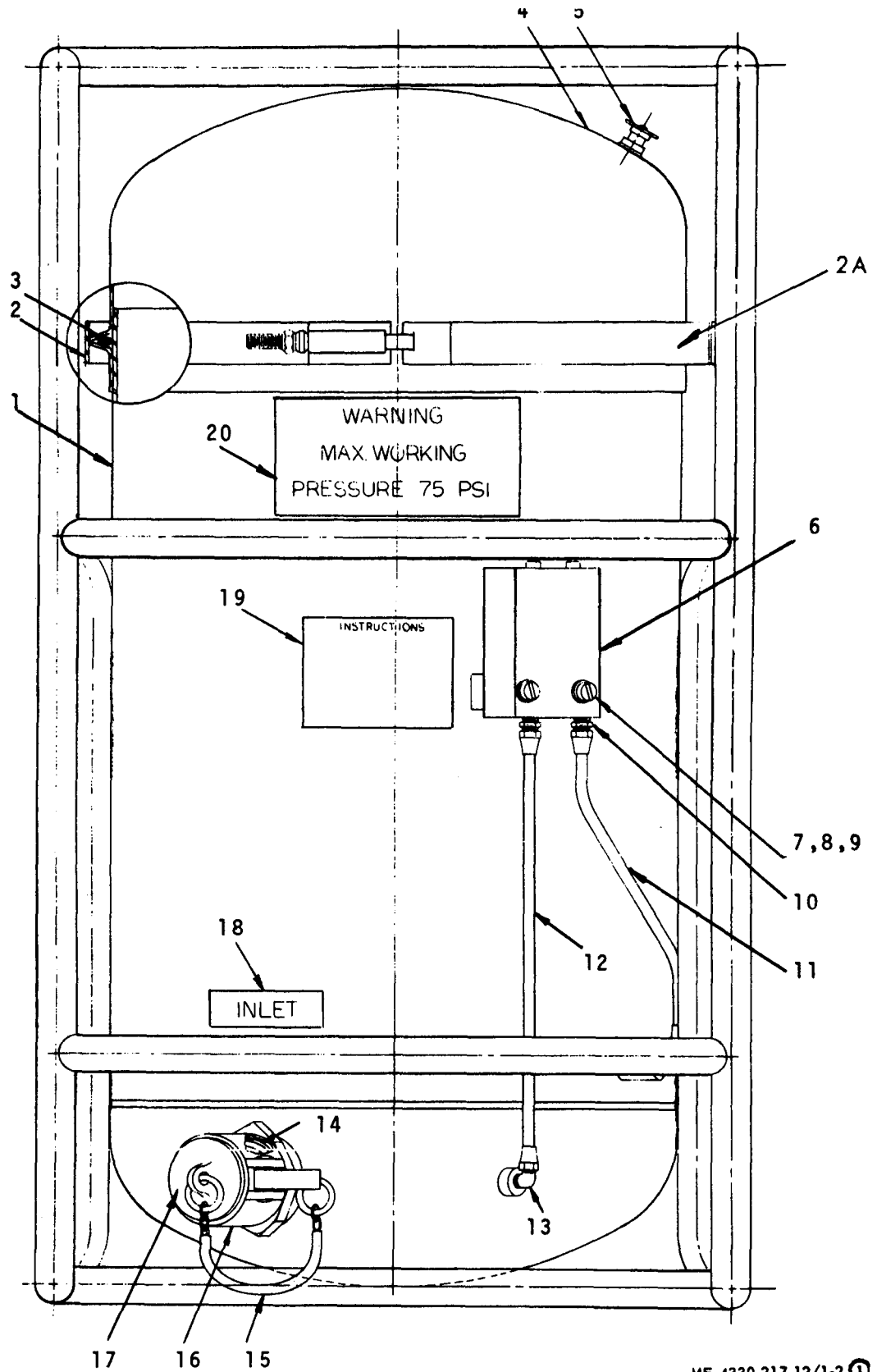

ME 4330-217-12/1-2 (1), C 3

Figure 1-2. Liquid filter separator (Sheet 1 of 2).

Page 1-5. Paragraph 1-5 **b (1) Canister**, should be identified as 1-5 **b (2) Canister**.

Paragraph 1-5 b (2). After Step (2),

add step (3).

(3) Selector Kit Assembly, Water and Solid Contamination. See figure 1-4.

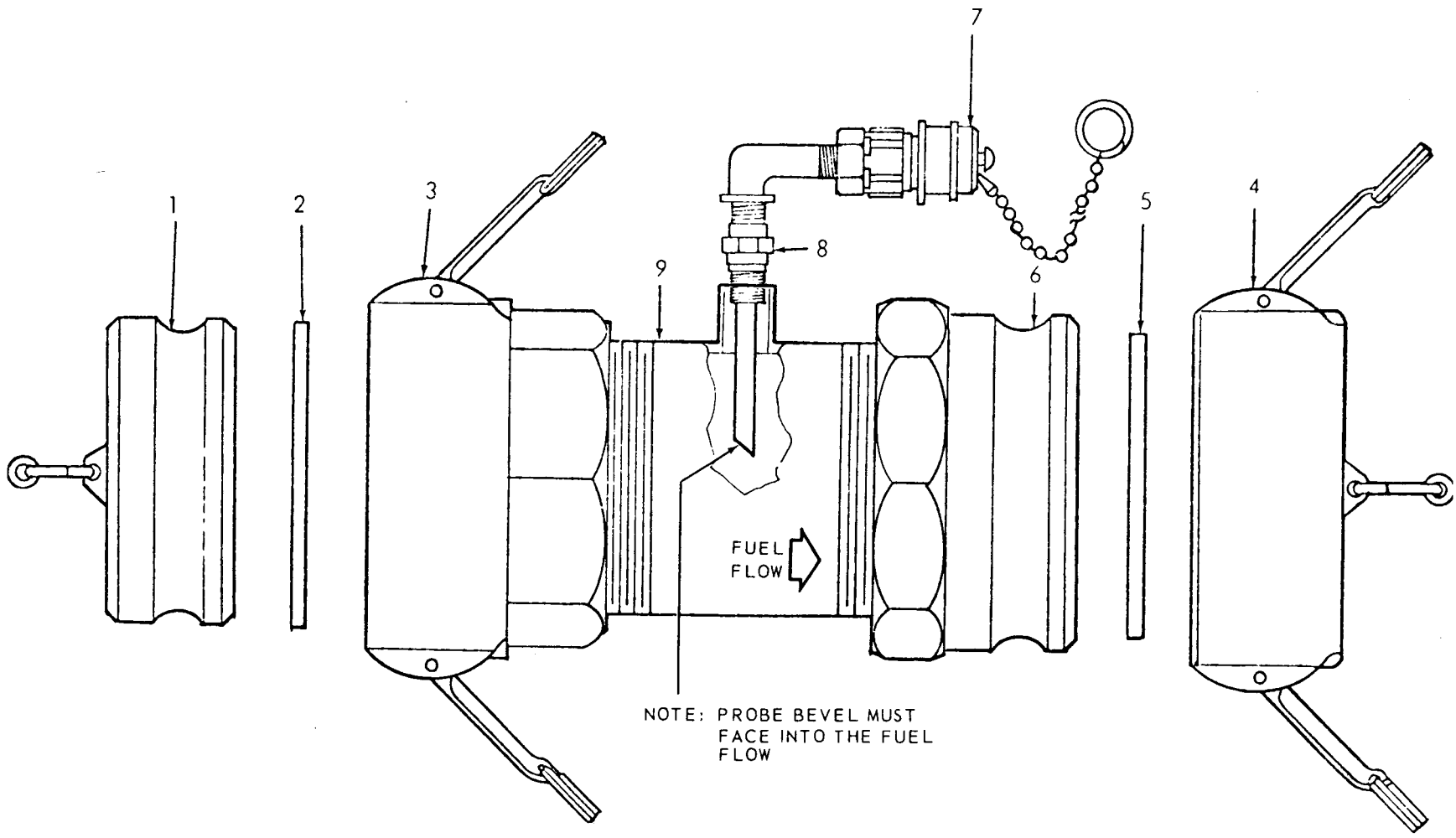

NOTE: PROBE BEVEL MUST
FACE INTO THE FUEL
FLOW

- 1 Dust Plug
- 2 Gasket
- 3 Female Coupling
- 4 Dust Cap
- 5 Gasket
- 6 Male coupling
- 7 Probe assembly
- 8 Hexagon Nut
- 9 Pipe Nipple

Figure 1-4. Adapter, water detector kit.

The Detector Kit Assembly is supplied with the 100 GPM Filter-Separator. It is required to attach the Fuel Contamination Test Kit (NSN 6640-00-244-9478) at the filter-separator outlet.

The test kit is used to determine if the filter-separator is filtering properly. Refer to figure 1-4 for identification of adapter components.

Page 1-5, paragraph 1-7 b (1). Change the contract number to read "DSA 700-72-C-9087".

Paragraph 1-7 b (5). Change the Part Number to read "1201-PG-2-2".

Page 2-1, paragraph 2-1 b. In line 9, starting with words "every 30 days . . .", the remainder of the paragraph is superseded as follows:

The Detector Kit Adapter contains a sampling probe which extends into the fuel flowing from the Filter-Separator Outlet. The Detector Kit is attached to the Adapter Probe. (The Test Kit, NSN 6640-00-244-9478) is not furnished with the filter separator but is authorized to be used with it.

Paragraph 2-2a (3) is superseded as follows:

(3) Slowly open air valve (5, figure 1-2, Sheet 1 of 2) to allow entrapped air to escape.

Paragraph 2-2a (6). After Step (6), add Step (7) as follows:

(7) Adapter Installation.

(a) Look at the direction of the arrow on hexagon nut (8, Fig. 1-4) to make sure the bevel on

the probe faces into the fuel flow, after the probe has been installed in pipe nipple (9, Figure 1-4).

(b) Remove dust cap from the Filter-Separator Outlet Coupling (Fig. 1-3).

(c) Remove dust plug (1, Fig. 1-4) from Adapter.

(d) Install or make sure that Gasket (2, fig. 1-4) has been installed in female coupling (3), and attach the adapter to the Filter-Separator Outlet Coupling (Figure 1-3).

Paragraph 2-2a (7). After step (7), add step (8).

(8) To take samples, attach test kit to Adapter probe as outlined in Test Kit Manual.

Paragraph 2-2b (3). In line 3, after the words "differential pressure indicator", add the word "gage".

Paragraph 2-2b (5). In line 1, after the words "differential pressure indicator", add the word "gage".

Paragraph 2-2b (6). In line 2, the word "slightly" is changed to read "slowly".

Page 2-2, paragraph 2-4a. In line 9, step "(1)" is superseded to read step "(2)". Check differential pressure . . .

Paragraph 2-4d. In line 10, step (1) is superseded to read step (2).

Page 3-1. Section II is superseded as follows:

Section II. PREVENTIVE MAINTENANCE CHECKS AND SERVICES

3-2. General

To insure that the filter separator is ready for operation at all times, it must be inspected systematically so that the defects may be discovered and corrected before they result in serious damage or failure. Defects discovered during operation of the unit shall be noted for future corrections, to be made as soon as an operation has ceased. Stop operation which would damage the equipment if operation were to continue. All deficiencies and shortcomings shall be recorded together with the corrective action taken on DA Form 2404, Equipment Inspection and Maintenance Worksheet, at the earliest opportunity. When performing your "Before Operation" (B) and "During Operation" (D) PMCS, always keep in mind the cautions and warnings. After operation, be sure to perform your (A) PMCS.

3-3. Preventive Maintenance Checks and Services

Refer to table 3-1 for preventive maintenance checks and services.

a. Item Number Column. Checks and services are numbered in chronological order regardless of interval. This column will be used as a source of item numbers for the "TM Item Number" column on DA Form 2404 in recording of PMCS.

b. Interval Columns. The columns headed "B", "D", "A", "W", and "M", will contain a dot (●) opposite the appropriate check indicating it is to be performed before, during, after, weekly or monthly.

c. Combat Operability Column. A dot (●) in the "C" column will identify combat operability checks for unit readiness reporting purposes.

d. Item to be Inspected Column. The items listed in this column are divided into groups and identifies the items to be inspected.

e. Procedures Column. This column contains a brief description of the procedure by which the check is to be performed.

f. Equipment will be Reported Not Ready (RED) Column. This column will contain the criteria which will cause the equipment to be classified as not ready (RED) because of inability to perform its primary mission.

NOTE
 If the equipment must be kept in continuous operation, check and service only those items that can

be checked and serviced without disturbing operation. Make the complete checks and services when the equipment can be shut down.

Table 3-1. Operator/Crew Preventive Maintenance Checks and Services

NOTE: Within designated interval, these checks are to be performed in the order listed.

Item No.	Interval					Item to be Inspected	Procedures Check for and have repaired or adjusted as necessary	Equipment Will Be Reported Not Ready (RED) If:
	B	D	A	W	M C			
1	●					Filter/Separator	Make a visual check for leaks, loose or missing bolts in cover assembly and other connections.	Leaking, loose connections or missing bolts.
2	●					Valves	Insure that all valves operate freely and don't leak.	Stuck or leaks.
3		●				Differential Pressure Gage	Check band reading to insure pressure reading in below the RED BAND on the gage. If in YELLOW, change elements after operation.	IN RED.
4	●					Ground Wire	Insure the ground wire is connected properly and is not broken.	Loose or broken.
5		●				Water Level Sight Gage	Check to insure ball floats freely.	Stuck.
6	●					Gaskets	Insure gaskets are in place and not leaking.	Leaking.
7			●			Dust caps & Plugs	Insure dust caps and plugs are installed after operation. If not installed, flush discharge hose before operation.	Not Installed.
8				●	●	Tank & Frame Assembly	Check Tank & Frame for dents, breaks and loose mounting bolts.	Frame is broken or mounting bolts are broken or missing.

Page 4-3. Section IV is superseded as follows:

Section IV. PREVENTIVE MAINTENANCE CHECKS AND SERVICES

4-8. General

To insure that the filter separator is ready for operation at all times, it must be inspected systematically so that the defects may be discovered and corrected before they result in serious damage or failure. Defects discovered during operation of the unit shall be noted for future corrections, to be made as soon as an operation has ceased. Stop operation which would damage the equipment if operation were to continue. All deficiencies and shortcomings shall be recorded together with the corrective action taken on DA Form 2404, Equipment Inspection and Maintenance Worksheet, at the earliest opportunity. When performing your "Before Operation" (B) and "During Operation" (D) PMCS, always keep in mind the cautions and warnings. After operation, be sure to perform your (A) PMCS.

49. Preventive Maintenance Checks and Services

Refer to table 4-1 for preventive maintenance checks and services.

a. *Item Number Column.* Checks and services are numbered in chronological order regardless of interval. This column will be used as a source of

item numbers for the "TM Item Number" column on DA Form 2404 in recording results of PMCS.

b. *Interval Columns.* The columns headed "B", "D", "A", "W", and "M", will contain a dot (●) opposite the appropriate check indicating it is to be performed Before, During, After, Weekly or Monthly.

c. *Combat Operability Column.* A dot (●) in the "C" column will identify combat operability checks for unit readiness reporting purposes.

d. *Item to be Inspected Column.* The items listed in this column are divided into groups and identifies the items to be inspected.

e. *Procedures Column.* This column contains a brief description of the procedure by which the check is to be performed.

f. *Equipment will be Reported Not Ready (RED) Column.* This column will contain the criteria which will cause the equipment to be classified as not ready (RED) because of inability to perform its primary mission.

NOTE

If the equipment must be kept in continuous operation, check and service only those items that can be checked and serviced without disturbing operation. Make the complete checks and services when the equipment can be shut down.

Table 4-1 Organizational Preventive Maintenance Checks and Services

Legend

Item No.	Interval							Item To be Inspected	Procedure	Equipment Will be Reported not Ready (RED) if:
	W	M	Q	S	A	B	H MI			
1	●							Water level sight gage	Inspect body of sight gage for breaks and cracks, replace defective sight gage or gasket.	Sight gage is leaking, or evidence of cracks of any length appear.
2								Valves	Check if all manual operated valves operate freely and stems are not bent or broken. Replace defective valves as necessary.	Manual operated valves won't operate freely.
3	●							Tank	Check tank for rust, clean and paint exposed surfaces.	

Page B-1. Appendix B is added after Appendix A as follows:

APPENDIX B

COMPONENTS OF END ITEMS LIST

Section I. INTRODUCTION

B-1. Scope

This appendix lists integral components of and basic issue items (BII) for the filter separator to help you inventory items required for safe and efficient operation.

B-2. General

The components of end item list are divided into the following sections:

a. Section II. Integral Components of the End Item. These items, when assembled, comprise the filter separator and must accompany it whenever it is transferred or turned in. These illustrations will help you identify these items.

b. Section III. Basic Issue Items. These are minimum essential items required to place the filter separator in operation, to operate it and to perform emergency repairs. Although shipped separately packed, they must accompany the filter separator during operation and whenever it is transferred between accountable officers. The illustrations will assist you with hard-to-identify items. This manual is your authority to requisition replacement BII based on Table(s) of Organization and Equipment (TOE)/Modification Table of Organization and Equipment (MTOE) authorization of the end item.

B-3. Explanation of Columns

a. Illustration. This column is divided as follows:

(1) Figure number. Indicates the figure number of the illustration on which the item is shown (if applicable).

(2) Item number. The number used to identify item called out in the illustration.

b. National Stock Number (NSN). Indicates the national stock number assigned to the end item which will be used for requisitioning.

c. Part Number (P/N). Indicates the primary number used by the manufacturer which controls the design and characteristics of the item by means of its engineering drawings, specifications, standards and inspection requirements to identify an item or range of items.

d. Description. Indicates the federal item name and, if required, a minimum description to identify the item.

e. Location. The physical location of each item listed is given in this column. The lists are designed to inventory all items in one area of the major item before moving on to an adjacent area.

f. Usable on Code. "Usable on" codes are included to help you identify which component items are used on the different models. Identification of the codes used in this list are:

<i>Code</i>	<i>Used on</i>
-------------	----------------

(Not Applicable)

g. Quantity Required (Qty Reqd). This column lists the quantity of each item required for a complete major item.

h. Quantity. This column is left blank for use during inventory. Under the received column, list the quantity you actually receive on your major item. The date columns are for use when you inventory the major item at a later date, such as for shipment to another site.

Section II. INTEGRAL COMPONENTS OF END ITEM

(1) ILLUSTRATION		(2)	(3)	(4)	(5)	(6)	(7)	(8) QUANTITY			
(a) FIGURE NO.	(b) ITEM NO.	NATIONAL STOCK NO.	PART NO. & FSCM	DESCRIPTION	LOCATION	USABLE ON CODE	QTY REQD	RCVD	DATE	DATE	DATE
1-2	27	5975-00-878- 3791	MIL-R-1161 (81349)	Ground rod assembly			1				
		4930-01-017- 3639	13220 E9406-1 (97403)	Water De- tector Kit			1				

Section III. BASIC ISSUE ITEMS

(1) ILLUSTRATION		(2)	(3)	(4)	(5)	(6)	(7)	(8) QUANTITY			
(a) FIGURE NO.	(b) ITEM NO.	NATIONAL STOCK NO.	PART NO. & FSCM	DESCRIPTION	LOCATION	USABLE ON CODE	QTY REQD	RCVD	DATE	DATE	DATE
				DATM 5- 4330-217-12			1				

Page C-5. Appendix Misadded after Appendix B as follows:

APPENDIX C

ADDITIONAL AUTHORIZATION LIST

Section I. INTRODUCTION

C-1. Scope

This appendix lists additional items you are authorized for the support of the 100 GPM filter separator which has an overpack kit that is shipped with each unit, and is listed in Section II (Additional Authorization List).

C-2. General

This list identifies items that do not have to accompany the filter separator and that do not have to be turned in with it. These items are authorized to

you by CTA, MTOE, TDA or JTA.

C-3. Explanation of Listing

National stock number, descriptions and quantities are provided to help you identify and request the additional items you require to support this equipment. "Usable on" codes are identified as follows:

<i>Code</i>	<i>Used on</i>
(Not Applicable)	

Section II. ADDITIONAL AUTHORIZATION LIST

(1) NATIONAL STOCK NUMBER	PART NUMBER & FSCM	(2) DESCRIPTION	USABLE ON CODE	(3) U/M	(4) QTY AUTH
5330-00-010-9842	49M23 (08181)	Gasket, cover		EA	4
4330-00-983-0998	MIL-F-52308 (81349)	Element		EA	5
5330-00-235-4716	13217 E5363 (97403)	Gasket, sight gage		EA	1
6640-00-244-9478	MDIGTP-323MM	Detector Kit, Water and Solid Contamination		EA	1

Appendix D is added after Appendix C as follows:

APPENDIX D

MAINTENANCE ALLOCATION CHART

Section I. INTRODUCTION

D-1. General

a. This section provides a general explanation of all maintenance and repair functions authorized at various maintenance levels.

b. Section II, designates overall responsibility for the performance of maintenance functions on the identified end item or component. The implementation of the maintenance functions upon the identified end item or component will be consistent with the assigned maintenance functions.

c. Section III, lists the special tools and test equipment required for each maintenance function as referenced from Section II (Not applicable).

d. Section IV, contains supplemental instructions or explanatory notes required for a particular maintenance function.

D-2. Explanation of Columns in Section II

a. Group Number, Column (1). The assembly group number is a numerical group assigned to each assembly. The assembly groups are listed on the MAC in disassembly sequence beginning with the first assembly removed in a top down disassembly sequence.

b. Assembly Group, Column (2). This column contains a brief description of the components of each assembly group.

c. Maintenance Functions, Column (3). This column lists the various maintenance functions (A through K). The upper case letter placed in the appropriate column indicates the lowest maintenance level authorized to perform these functions. The active repair time required to perform the maintenance function is included directly below the symbol identifying the category of maintenance. The symbol designations for the various maintenance levels are as follows:

- C - Operator or crew
- O - Organizational maintenance
- F - Direct support maintenance
- H - General support maintenance
- D - Depot maintenance

The maintenance functions are defined as follows:

- A--Inspect. To determine serviceability of an item by comparing its physical, mechanical, and electrical characteristics with established standards.
- B--Test. To verify serviceability and to detect electrical or mechanical failure by use of test equipment.
- C--Service. To clean, to preserve, to charge, and to add fuel, lubricants, cooling agents, and air.
- D--Adjust. To rectify to the extent necessary to bring into proper operating range.
- E--Align. To adjust specified variable elements of an item to bring to optimum performance.
- F--Calibrate. To determine the corrections to be made in the readings of instruments or test equipment used in precise measurement. Consists of the comparison of two instruments, one of which is a certified standard of known accuracy, to detect and adjust any discrepancy in the accuracy of the instrument being compared with the certified standard.
- G--Install. To set up for use in an operational environment such as an emplacement, site, or vehicle.
- H--Replace. To replace unserviceable items with serviceable like items.
- I--Repair. Those maintenance operations necessary to restore an item to serviceable condition through correction of material damage or a specific failure. Repair may be accomplished at each level of maintenance.
- J--Overhaul. Normally, the highest degree of maintenance performed by the Army in order to minimize time work is in process consistent with quality and economy of operation. It consists of that maintenance necessary to restore an item to completely serviceable condition as prescribed by maintenance standards in technical publications for each item of equipment. Overhaul normally does not return an item to like new, zero mileage, or zero hour condition.
- K--Rebuild. The highest degree of material maintenance. It consists of restoring equipment as nearly as possible to new condition in accordance with original manufacturing standards. Rebuild is performed only when required by operational considerations or other paramount factors and then only at the depot maintenance level. Rebuild reduces to zero the hours or miles the equipment, or component thereof, has been in use.

The maintenance functions are defined as follows:

d. Tools and Equipment, Column (4). This column not applicable.

e. Remarks, Column (5). This column is provided for referencing by code the remarks (Section IV) pertinent to the maintenance functions.

D-3. Explanation of Columns in Section III

(Not applicable).

D-4. Explanation of Columns in Section IV

a. Reference Code. This column consists of two letters separated by a dash (entered from column 5 of Section II). The first letter references alpha se-

quence in Column 5 and the second letter references a maintenance function, Column 3, A through K

b. Remarks. This column lists information pertinent to the maintenance function to be performed (as indicated in Section II).

Section II. MAINTENANCE ALLOCATION CHART

(1) Group No.	(2) Assembly Group	(3) Maintenance Function											(4) Tool and Equipment	(5) Remarks	
		A	B	C	D	E	F	G	H	I	J	K			
01	COVER, CANISTERS AND ELEMENTS														
	Cover Clamp and Tank Cover	C							C						
		0.1							0.3						
	Canisters and Band	C		C					C		O				A-C, B-I
		0.5		0.8					1.0		1.0				
	Cover Gasket and Elements	C							C						
		0.1							0.3						
02	VALVES, LINES AND FITTINGS														
	Water Drain Valve	C							0						
		0.1							0.3						
	Air Vent Valve	C							0						
		0.1							0.3						
	Lines and Fittings	C							0						
		0.1							0.5						
	Coupler and Adapter	C							0						
		0.3							0.8						
03	SIGHT GAGE AND DIFFERENTIAL PRESSURE INDICATOR														
	Sight Gage Water Level	0							0						
		0.1							0.5						
	Differential Pressure Indicator	C	O	O					0						
		0.1	0.8	0.5					1.0						
04	TANK AND FRAME ASSEMBLY														
	Tank and Frame	C							0		0				C-I
		0.5							1.0		3.0				
	Rod Ground Assembly	C							0						
		0.3							1.0						
	Data Instructions and Warning Plates	C							0						
		0.1							1.0						

Section IV. Remarks

Reference Code	Remarks
A-C	Service consists of cleaning of the canister with solvent at each element change.
B-I	Repair consists of replacing the canisters and spring tension washers.
C-I	Repair includes straightening and welding of the frame by experienced aluminum welder.

Appendix E is added after Appendix D as follows:

APPENDIX E

REPAIR PARTS AND SPECIAL TOOLS LISTS

Section I. INTRODUCTION

E-1. Scope

a. This appendix lists repair parts, special tools, test, and support equipment required for the performance of organizational maintenance of the Liquid Fuel Filter-Separator.

b. Repair parts listed represent those authorized for use at the organizational level and will be requisitioned on an "as required" basis until stockage is justified by demand in accordance with AR 740-2.

E-2. General

This Repair Parts and Special Tools List is divided into the following sections:

a. Items Troop Installed or Authorized List--Section II. A list in alphabetical sequence, of items which, at the discretion of the unit commander, may accompany the end item, but are not subject to be turned in with the end item.

b. Repair Parts List--Section III. A list of repair parts authorized at the organizational level for the performance of maintenance. The list also includes parts which must be removed for replacement of the authorized parts. Parts lists are composed of assembly groups in ascending numerical sequence, with the parts in each group listed in figure and item number sequence.

c. Special Tools List--Section IV. (Not applicable).

d. Federal Stock Number and Reference Number Index--Section V. A list in ascending numerical sequence, of all Federal stock numbers appearing in the listings followed by a list, in alphanumeric sequence, of all reference numbers appearing in the listings. Federal stock number and reference numbers are cross-referenced to each illustration figure and/or item number.

E-3. Explanation of Columns

The following provides an explanation of columns found in the tabular lists in Sections III and V.

a. Source, Maintenance, and Recoverability Codes (SMR):

(1) Source code indicates the source for the

listed items. Source codes are:

<i>Code</i>	<i>Explanation</i>
P	Repair parts, special tools, and test equipment supplied from GSA/DSA, or Army supply system and authorized for use at indicated maintenance levels.
P2	Repair parts, special tools, and test equipment which are procured and stocked for insurance purposes because combat or military essentiality of the end item dictates that a minimum quantity be available in the supply system.
P9	Assigned to items which are NSA design controlled: unique repair parts, special tools, test, measuring, and diagnostic equipment which are stocked and supplied by the Army COMSEC Logistic System and which are not subject to the provisions of AR 380-41.
P10	Assigned to items which are NSA design controlled: special tools, test, measuring, and diagnostic equipment for COMSEC support which are accountable under the provisions of AR 380-41 and which are stocked and supplied by the Army COMSEC Logistic System.
M	Repair parts, special tools, and test equipment which are not procured or stocked as such in the supply system but are to be manufactured at indicated maintenance levels.
A	Assemblies which are not procured or stocked as such, but are made up of two or more units. Such component units carry individual stock numbers and descriptions, are procured and stocked separately, and can be assembled to form the required assembly at indicated maintenance levels.
X	Parts and assemblies that are not procured or stocked because the failure rate is normally below that of the applicable end item or component. The failure of such part or assembly should result in retirement of the end item from the supply system.
X1	Repair parts which are not procured or stocked. The requirement for such items will be filled by the next higher assembly or component.
X2	Repair parts, special tools, and test equipment which are not stocked and have no foreseen mortality. The indicated maintenance level requiring such repair parts will attempt to obtain the parts through cannibalization or salvage. The item may be requisitioned with exception data, from the end item manager for immediate use.
G	Major assemblies that are procured with PEMA funds for initial issue only as exchange assemblies at DS and GS level. These assemblies will not be stocked above the DS and GS level or returned to depot supply level.

NOTE

Cannibalization or salvage may be used as a source of supply for any items source coded above except those coded X1 and aircraft support items as restricted by AR 700-42.

(2) Maintenance code indicates the lowest

level of maintenance authorized to install the repair part and/or use the special tool or test equipment for each application. Capabilities of higher maintenance levels are considered equal or better. Maintenance codes are:

Code	Explanation
C	Crew/Operator
O	Organizational maintenance

(3) Recoverability code indicates whether un-serviceable items should be returned for recovery or salvage. Items not coded are nonrecoverable. Recoverability codes are:

Code	Explanation
R	Repair parts (assemblies and components), special tools, and test equipment which are considered economically repairable at direct and general support maintenance levels. When the item is no longer economically repairable, it is normally disposed of at the GS level. When supply considerations dictate, some of these repair parts may be listed for automatic return to supply for depot level repair as set forth in AR 710-50. When so listed, they will be replaced by supply on an exchange basis.
S	Repair parts, special tools, tools, equipment, and assemblies which are economically repairable at DS and GS activities and which normally are furnished by supply on an exchange basis. When items are determined by a GS to be economically repairable, they will be evacuated to a depot for evaluation and analysis before final disposition.
T	High dollar value recoverable repair parts, special tools, and test equipment which are subject to special handling and are issued on an exchange basis. Such items will be repaired or overhauled at depot maintenance activities only. No repair may be accomplished at lower levels.
U	Repair parts, special tools, and test equipment specifically selected for salvage by reclamation units because of their precious metal content, critical materials, high dollar value, or reusable casings or castings.

b. Federal Stock Number. Indicates the Federal stock number assigned to the item and will be used for requisitioning purposes.

c. Description. Indicates the Federal item name and a minimum description required to identify the item. The last line indicates the reference number followed by the applicable Federal Supply Code for Manufacturer (FSCM) in parentheses. The FSCM is used as an element in item identification to designate manufacturer or distributor or Government agency, etc., and is identified in SB 708-42. Items that are included in kits and sets are listed below the name of the kit or set with quantity of each item in the kit or set indicated in front of the item name.

d. Unit of Measure (U/M). Indicates the standard or basic quantity by which the listed item is used in performing the actual maintenance function. This measure is expressed by a two-character alphabetical abbreviation, e.g., ea, in, pr, etc., and is the basis used to indicate quantities and allowances in subsequent columns.

e. Quantity Incorporated in Unit. Indicates the quantity of the item used in the breakout shown on the illustration figure, which is prepared for an assembly group or an assembly. A "V" appearing in this column in lieu of a quantity indicates that no specific quantity is applicable, e.g., shims, spacers, etc.

f. Fifteen-Day Organizational Maintenance Allowance.

(1) Items authorized for use as required but not for initial stockage are identified with an asterisk in the allowance column.

(2) The allowance columns are divided into four subcolumns. Indicated in each subcolumn is the total quantity of special tools authorized for the number of equipments supported. (Not applicable).

g. Illustration. This column is divided as follows:

(1) **Figure number.** Indicates the figure number of the illustration in which the item is shown.

(2) **Item number.** Indicates the callout number used to reference the item on the illustration.

E-4. Special Information

a. The basis of issue for authorized special tools, test, and support equipment is the number of end items of equipment supported and the number of maintenance personnel allocated to perform the required maintenance operations.

b. Parts which require manufacture or assembly at a level higher than that authorized for installation will indicate in the source column the higher level.

E-5. How to Locate Repair Parts

a When Federal stock number or reference number is unknown:

(1) Using the table of contents, determine the assembly group within which the repair part belongs. This is necessary since illustrations are prepared for assembly groups, and listings are divided into the same groups.

(2) Find the illustration covering the assembly group to which the repair part belongs.

(3) Identify the repair part on the illustration and note the illustration figure and item number of the repair part.

(4) Using the repair parts listing, find the assembly group to which the repair part belongs and locate the illustration figure and item number noted on the illustration.

b. When the Federal stock number or reference number is known:

(1) Using the Index of Federal Stock Numbers

and Reference Numbers find the pertinent Federal Stock Number or reference number. This index is in ascending FSN sequence followed by a list of reference numbers in ascending alphanumeric sequence, cross-referenced to the illustration figure number and item number.

(2) Using the repair parts listing, find the assembly group of the repair part and the illustration

figure number and item number referenced in the Index of Federal Stock Numbers and Reference Numbers.

E-6. Abbreviations

NPT National pipe thread
 UNC Unified National Coarse
 UNF Unified National Fine

Section II. ITEMS TROOP INSTALLED OR AUTHORIZED LIST

(1) SMR CODE	(2) NATIONAL STOCK NUMBER	REF NO & MFG CODE	(3) DESCRIPTION	(4) UNIT OF USABLE ON CODE MEAS	(5) QTY AUTH
	7520-559-9618		CASE, MAINTENANCE AND OPERATION MANUALS	EA	1

Section III. In line 1, after “clamp, cover” and the following: Column 1, “PBOZZ”; column 3, “Coupler, ‘V’, retainer for models other than Keane,

P/N 13220E0991 (97403); column 4, “EA”; column 5, “1”; column 6, “*”; column 7 (a), “1-2”; column 7 (b), “2”.

By Order of the Secretary of the Army:

BERNARD W. ROGERS
General, United States Army
Chief of Staff

Official:

J. C. PENNINGTON
Brigadier General, United States Army
The Adjutant General

Distribution:

To be distributed in accordance with DA Form 12-25A, operator maintenance requirements for petroleum.

CHANGE }
 No. 1 }

HEADQUARTERS
 DEPARTMENT OF THE ARMY
 WASHINGTON, DC, 30 August 1974

**Operator and Organizational Maintenance Manual
 (Including Repair Parts and Special Tools List)
 for
 FILTER-SEPARATOR, LIQUID FUEL; 100 GPM;
 FRAME-MOUNTED (KEENE CORP. MODEL 844-5-V-100AL)
 (VELCON FILTERS, INC. MODEL V-1520-ANZ) FSN 4330-491-4957**

TM 5-4330-217-12, 5 April 1973, is changed as follows:

Title is changed to read as shown above.

Reverse of Cover. Add to warning:

Cleaning solvent, P-D-680, is potentially dangerous chemical. Do not use near open flame. Flash point of solvent is 100° F. - 138° F.

Page 1-1. Paragraph 1-1 is superseded as follows:

1-1. Scope. This manual is for your use in operating and maintaining the 100 GPM filter-separators (Keene Corp. Model 844-5-V-100AL and Velcon Filters, Inc. Model V-1520-ANZ).

Paragraph 1-3. Lines 5 through 8 are changed to

read: "Commander, US Army Troop Support Command, ATTN: AMSTS-MPP, 4300 Goodfellow Boulevard, St. Louis, MO 63120."

Page 1-1, paragraph 1-5a. The first sentence is changed to read as follows: "The filter-separators are designed to filter and separate particles of contamination and water from light petroleum fuels. The Velcon filter-separator uses a gage to indicate the pressure differential, rather than a pressure indicator."

Page 1-2. Legend for figure 1-1, the callout 6 is changed to read: "6 Differential pressure indicator (gage)".

Page 1-4. Figure 1-3 is added as follows:

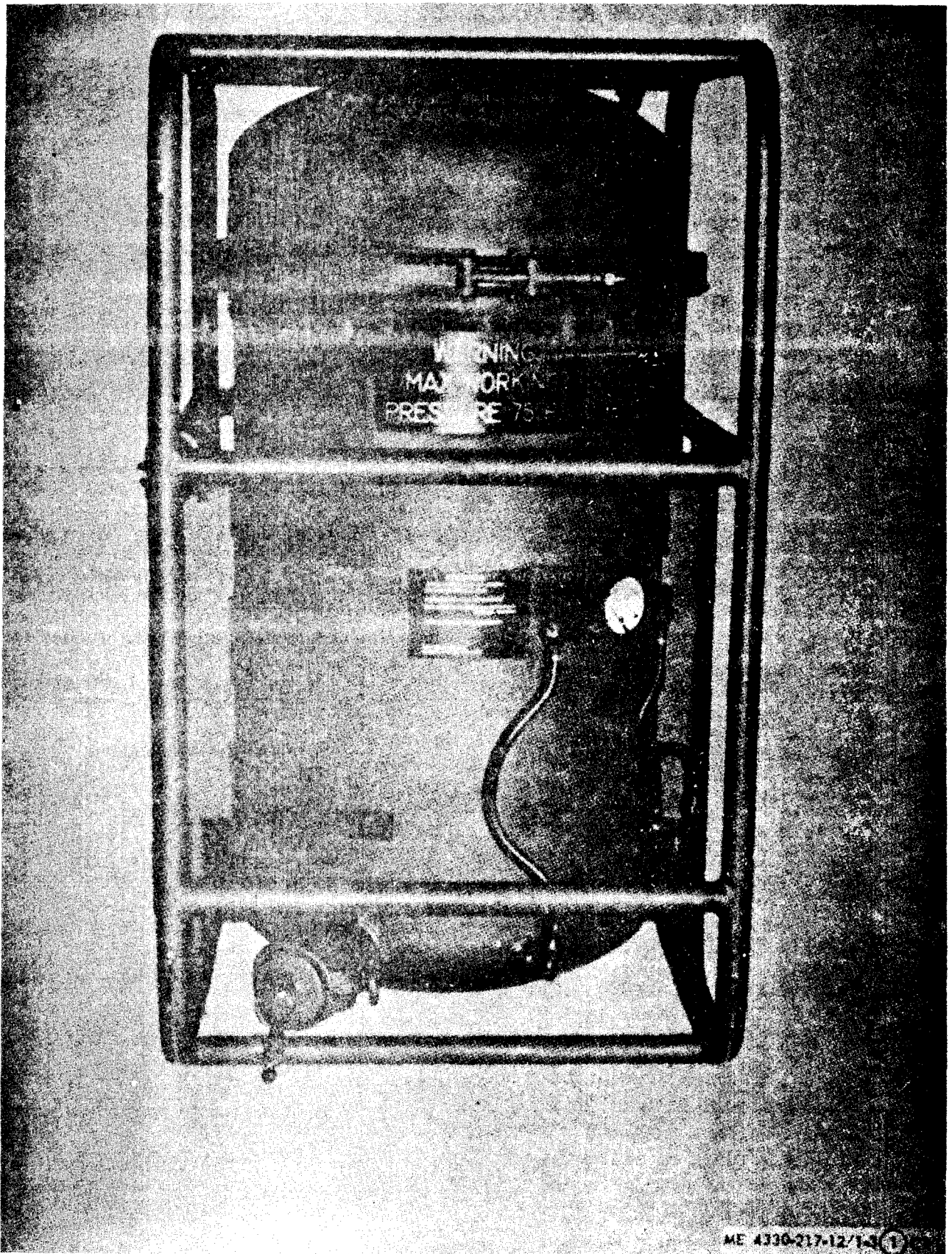

Figure 1-3, Liquid filter-separator (Velcon Model V-1520-ANZ) (sheet 1 of 2).

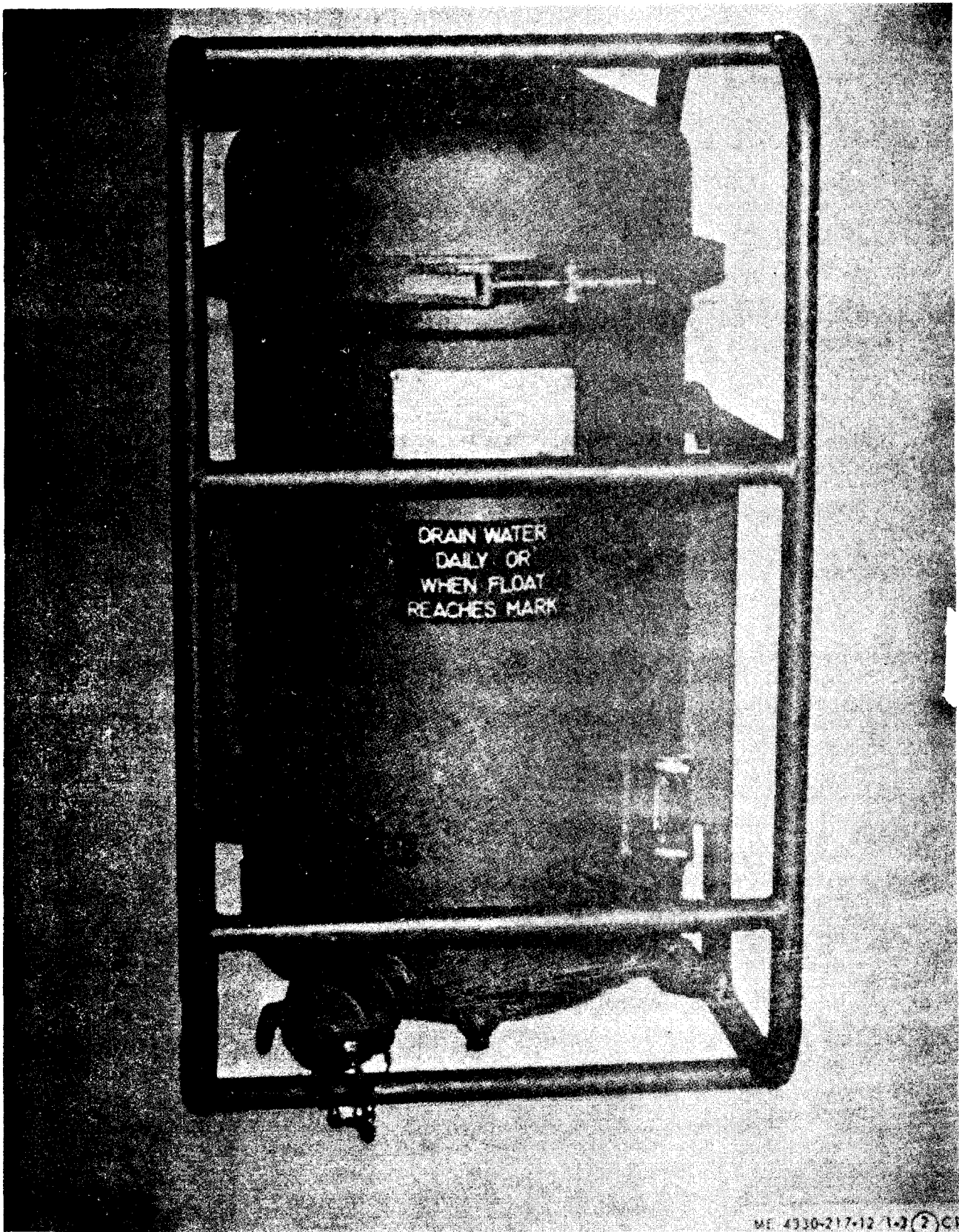

Figure 1-3. Liquid filter-separator (Velcon Model V-1520-ANZ) (sheet 2 of 2).

Page 1-5. Paragraph 1-6 is superseded as follows:

1-6. Differences in Models. The differences in model between the Model 844-5-V-100AL and Model V-1520-ANZ filter-separators are the Model 844-5-V-100AL has a pop-up-type fuel pressure indicator and the Model V-1520-ANZ filter-separator has an indicating-type gage.

Paragraph 1-7b (1.1) is added as follows:

- (1.1) *Identification*
 - Manufacturer Velcon Filters, Inc.
 - Model Number V-1520-ANZ
 - Federal Stock No. 4330-491-4957
 - Contract No DSA 700-72-C-9687
 - Specification No. 52556C

Paragraph 1-7b (5.1) is added as follows:

- (5.1) *Differential pressure indicator (Model V-1520-ANZ)*
 - Part Number 1201-PG-1
 - Manufacturer Orange Research Inc.
 - Federal Stock No. None assigned

Page 2-1. In the warning for section I, line 6, add: "Make sure paint has been removed from frame at point ground wire clamp is to be placed before installing ground wire clamp to frame."

Paragraph 2-2a (3). In line 1, "slightly" is changed to read "slowly".

Paragraph 2-2a (6) is superseded as follows:

(6) Once each day, open the air vent valve (5, fig. 1-2) slowly during operation to release entrapped air from the filter-separator. When all entrapped air has escaped, a small amount of fuel will come out of the valve. To open the vent valve, push DOWN and TURN until the wing is under the holddown. To close, reverse the procedure.

Paragraph 2-2b (3). In line 3, after "pressure indicator, add "(gage)" before reference (6, fig. 1-2).

Paragraph 2-2b (5). Add a new sentence as follows: "Change filter elements (para 3-5) immediately if the differential pressure gage readings (Model V-1520-ANZ filter-separator) are in any portion of the red band."

Page 2-2. Paragraph 2-4a (3) is added as follows:

(3) For Model V-1520-ANZ filter-separators, check the pressure differential gage periodically to be sure the pressure reading is below the red band on the gage.

Paragraph 2-4b (5) is added as follows:

(5) For Model V-1520-ANZ filter-separators, check differential pressure gage periodically to be sure the pressure reading is below the red band on the gage.

Paragraph 2-4c (4) is added as follows:

(4) For Model V-1520-ANZ filter-separator, check differential pressure gage periodically to be sure the pressure reading is below the red band on the gage.

Paragraph 2-4d (3) is added as follows:

(3) For Model V-1520-ANZ filter-separator, check differential pressure gage periodically to be sure the

pressure reading is below the red band on the gage.

Paragraph 2-4e (3) is added as follows:

(3) For Model V-1520-ANZ filter-separator, check differential pressure gage periodically to be sure the pressure reading is below the red band on the gage. Page 3-2, table 3-1. Item 3 is changed to read as follows: "Differential pressure indicator (gage)"; add to column 4: "For Model V-1520-ANZ, check that the reading is below red band on gage face."

Page 4-1. Paragraph 4-1d is added as follows:

d. Inspect differential pressure indicator (gage) for damage, loose mounting, broken glass.

Paragraph 4-2g. Add the following "Make sure paint has been removed from frame at point ground wire clamp is to be placed before attaching ground wire clamp to frame."

Page 4-5, table 4-2. Item 1, add to "Malfunction" column: "YELLOW BAND READING ON DIFFERENTIAL PRESSURE GAGE (MODEL V-1520-ANZ)".

Item 2, add to "Malfunction" column: "RED BAND READING ON DIFFERENTIAL GAGE (MODEL V-1520-ANZ)".

In Step 3, add "(gage)" after "pressure indicator".

Paragraph 4-12d (1). In line 2, add "or equivalent" after "MIL-S-7916".

Page 4-6, paragraph 4-13b. Add a new sentence as follows: "For Model V-1520-ANZ filter-separators, when the pressure differential equals or exceeds 20 p.s.i., the readings are in the yellow band range on the gage. When the pressure differential equals or exceeds 35 p.s.i., the readings are in the red band range on the gage."

Paragraph 4-15a (4) is added as follows:

(4) *Velcon Model V-1520-ANZ filter-separator gage.*

(a) Disconnect the tube assembly coupling nuts from elbows (3, fig. 4-3).

(b) Remove screws (4) and remove pressure gage.

(c) Place gage in padded vise (do not clamp too tight) and remove the intake connector (8) from the gage carefully. Remove piston (9) and spring (10).

(d) Remove outlet connector (8).

(e) Clean all residue from the piston, spring, and fuel passages in the gage with clean fuel or cleaning solvent, using a lint-free cloth.

CAUTION

Do not submerge gage in cleaning solution. Do not use abrasives to clean residue from components.

WARNING

Cleaning solvent, P-D-680, used for cleaning, is potentially dangerous chemical. Do not use near open flame.

Page 4-7. Figure 4-3 is added as follows:

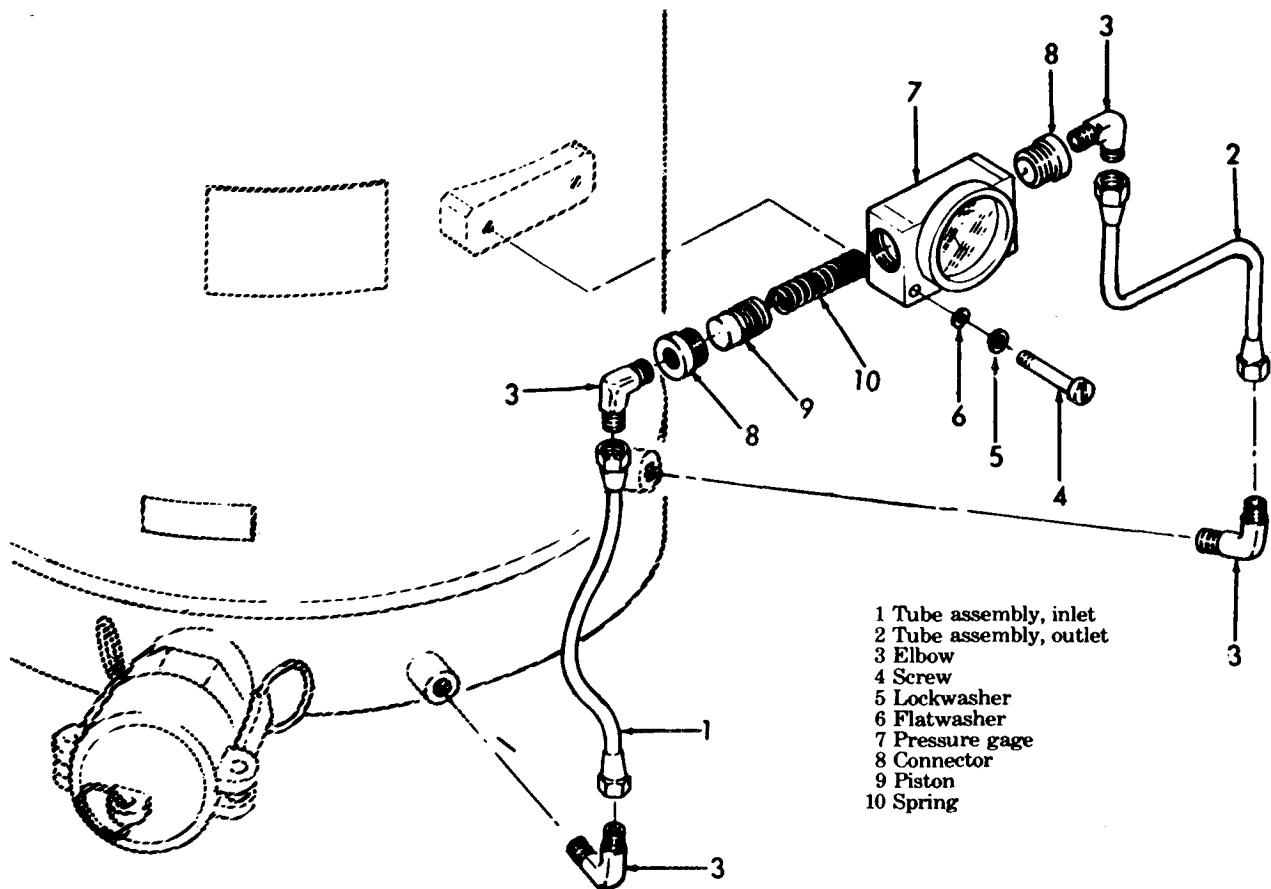

Figure 4-3. Differential pressure gage
(Velcon Model V-1520-ANZ).

Page 4-8, paragraph 4-15c (2). In line 4, add "or equivalent" after "MIL-S-7916".

Paragraph 4-15c (4) is added as follows:

(4) *Velcon Model V-1520-ANZ filter-separator.*

(a) Install elbow (3, fig. 4-3) in outlet side of gage.

(b) Install spring (10) and piston (9) in gage and secure in place with connector inlet connector (8).

(c) Install gage on filter-separator and secure in the screws and washers.

(d) Install tube assemblies to elbows and secure in place.

Paragraph 4-16a. After second sentence, line 7, add: "for Model V-1520-ANZ filter-separator readings for 20 p.s.i. \pm 15% are in the yellow band on the gage and readings of 35 p.s.i. \pm 15% are in the red band on the gage"

Paragraph 4-16b. In line 3, add "(gage)" after "Button indicators".

Paragraph 4-18b. In line 5, add "or equivalent" after "MIL-S-7916".

Page B-2, section II. Group 03, line 4 is changed to

read as follows: Column 2, "Differential Pressure Indicator (gage)"; Column C, add "0/0.5"; and Column 5 "(Remarks)", add "D-C".

Section IV. Add a new line as follows:

D-C Service consists of removing and cleaning differential pressure indicator (gage), piston, spring, and fuel passages.

Page C-4, line 3, column 2. Add FSN "4330-389-4834" for P/N 13217E5354.

Line 18 is added as follows: Column 1, "PO"; Column 3, "TUBE ASSY., (MODEL V-1520-ANZ), 13217E5365-4"; Column 4, "EA"; Column 5, "(2)"; and Column 7, Fig. "4-3, 1 & 2".

Page C-5. Add after line 10: Column 1, "PO"; column 3, "DIFFERENTIAL PRESSURE INDICATOR ASSEMBLY (Model V-1520-ANZ)", P/N 1201-RG1 (30839)": column 4. "EA": column 5. "1"; column 7, fig. "4-3, item 7".

Page I-1. Subject D, line 5, is changed to read as follows: "Differential pressure indicator (gage)".

Subject M. Lines 14, 15 and 16 are changed to read as follows: "Differential pressure indicator (gage)".

By Order of the Secretary of the Army:

CREIGHTON W. ABRAMS
General, *United States Army*
Chief of Staff

Official:

VERNE L. BOWERS

Major General, United States Army
The Adjutant General

Distribution:

To be distributed in accordance with DA Form 12-25A, (qty rqr block No. 153) Operator maintenance requirements for Petroleum Distribution.

OPERATOR AND ORGANIZATIONAL
MAINTENANCE MANUAL
INCLUDING REPAIR PARTS AND SPECIAL TOOLS LIST
FILTER-SEPARATOR, LIQUID FUEL; 100 GPM;
FRAME MOUNTED (KEENE CORP. MODEL 844-5-V-100AL)
FSN 4330-491-4957

		Paragraph	Page
CHAPTER	1. INTRODUCTION		
Section	I. General	1-1	1-1
	III. Description and Data	1-5	1-1
CHAPTER	2. OPERATING INSTRUCTIONS		
Section	I. Operating Procedures	2-1	2-1
	II. Operation Under Unusual Conditions	2-4	2-1
CHAPTER	3. OPERATOR/CREW MAINTENANCE INSTRUCTIONS		
Section	I. Lubrication Instructions	3-1	3-1
	II. Preventive Maintenance	3-2	3-1
	III. Troubleshooting	3-4	3-3
	IV. Maintenance of Filter Separator	3-5	3-3
CHAPTER	4. ORGANIZATIONAL MAINTENANCE INSTRUCTIONS		
Section	I. Service Upon Receipt of Material	4-1	4-1
	II. Movement to a New Worksite	4-3	4-2
	III. Repair Parts, Special Tools and Equipment	4-5	4-3
	IV. Preventive Maintenance Checks and Services	4-8	4-3
	v. Troubleshooting	4-10	4-5
	VI. Maintenance of Valves, Lines and Fittings	4-11	4-5
	VII. Maintenance of Water-Level Sight Gage and Differential Pressure Indicator	4-13	4-5
	VIII. Maintenance of Tank and Frame Assembly	4-17	4-8
APPENDIX	A. REFERENCES		A-1
	B. MAINTENANCE ALLOCATION CHART		B-1
	C. ITEMS TROOP INSTALLED OR AUTHORIZED AND ORGANIZATIONAL MAINTENANCE REPAIR PARTS AND SPECIAL TOOLS LIST		C-1
Section	I. Introduction		C-1
	II. Items Troop Installed or Authorized List		C-3
	III. Repair Parts for Organizational Maintenance		C-4
Group	01. Cover, Canisters, and Elements		C-4
	02. Valves, Lines, and Fittings		C-4
	03. Sight Gage, and Differential Pressure Indicator		C-5
	04. Tank and Frame Assembly		C-5
Section	IV. Special Tools List (Nonapplicable)		C-6
	V. Index of Federal Stock Numbers and Reference Numbers		C-6
INDEX			I-1

CHAPTER 1

INTRODUCTION

Section I. GENERAL

1-1. Scope

This manual contains instructions for the use of the personnel operating and maintaining the Keene Corporation Model 844-5-V-100AL filter separator.

1-2. Maintenance Forms and Records

Maintenance forms, records, and reports which are to be used by maintenance personnel at all maintenance levels are listed in and prescribed in FM ~~30-750~~. ~~738-750~~

1-3. Reporting of Errors

Reports of errors, omissions, and recommendations

for improving this publication by the individual user is encouraged. Reports should be submitted on DA Form 2028, Recommended Changes to Publications, and forwarded direct to Commanding General, U. S. Army Mobility Equipment Command, ATTN : AMSME-MPP, St. Louis, Missouri 63120. A reply will be forwarded directly to you.

1-4. Administrative Storage and Demolition

a. For information on administrative storage of this equipment, refer to TM 740-90-1.

b. For information on the demolition of this equipment refer to TM 750-244-3.

Section II. DESCRIPTION AND DATA

1-5. Description

a. *General Description.* The Model 844-5-V-100AL filter separator (fig. 1-2) is designed to filter and separate particles of contamination and water from light petroleum fuels. It is capable of handling fuel at a rate of 100 gallons per minute (GPM). It

consists of a vessel with a removable cover, five replaceable filter elements and canisters, a differential pressure indicator, a water-level sight gage, a manual water drain valve, a manual air vent valve, and inlet and outlet connections for quick disconnect couplings.

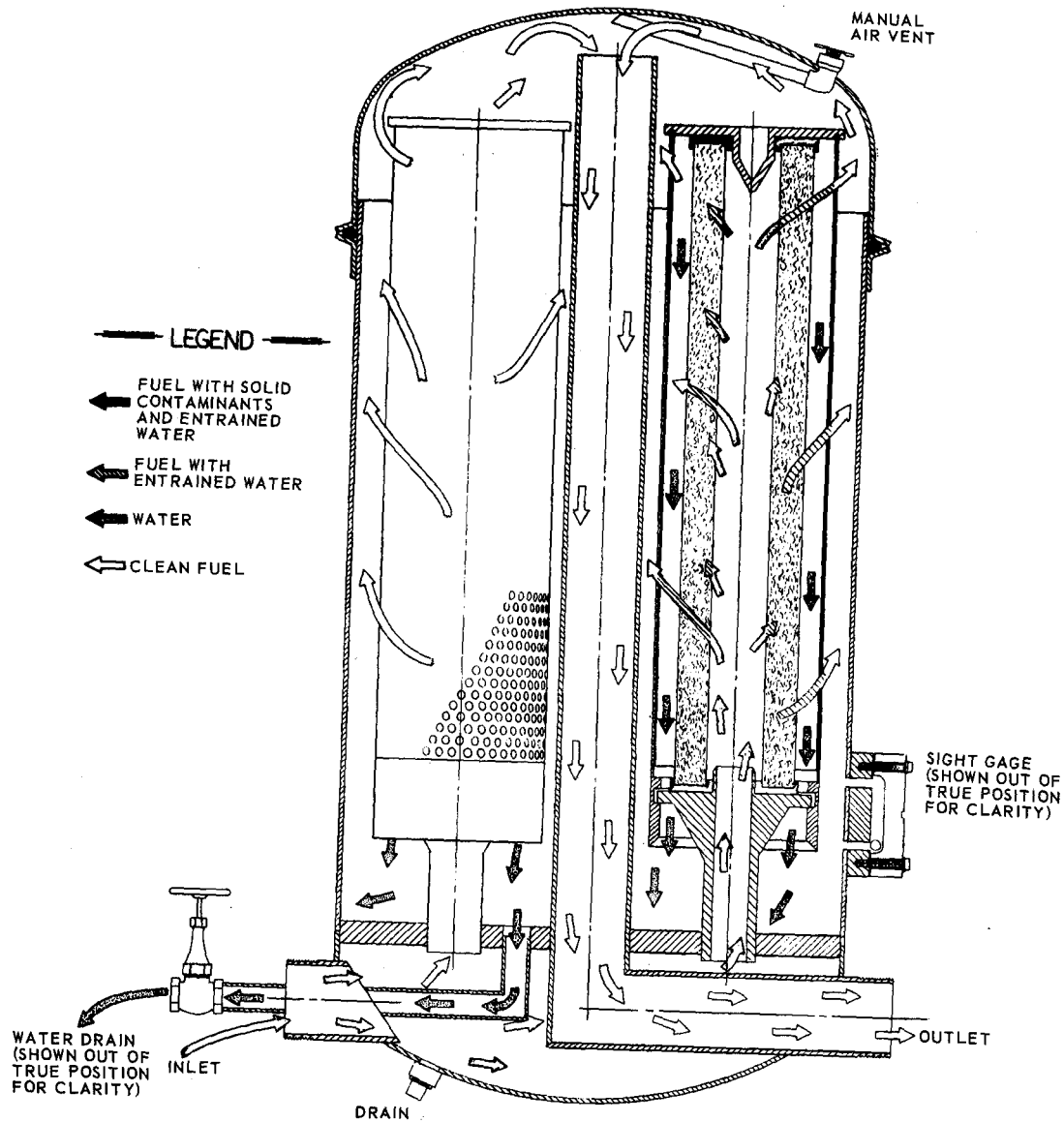

ME 4330-217-12/1-1

- | | | |
|-----------------------------------|--------------------------|---------------------------|
| 1 Tank & frame assembly | 15 Chain, security | 28 Plate, data |
| 2 Clamp, cover | 16 Coupler | 29 Sight gage assembly |
| 3 Gasket, cover | 17 Plug, dust | 30 Screw, machine |
| 4 Cover assembly | 18 Plate, data | 31 Washer, flat |
| 5 Valve, air vent | 19 Plate, data | 32 Body, sight gage |
| 6 Differential pressure indicator | 20 Plate, data | 33 Gasket, sight gage |
| 7 Screw, machine | 21 Clamp, canister band | 34 Ball, float |
| 8 Washer, flat | 22 Element | 35 plate, data |
| 9 Washer, lock | 23 Canister assembly | 36 Valve, water drain |
| 10 Connector, male | 24 Screw, drive | 37 Plug, pipe |
| 11 Tube assembly | 25 Plate, identification | 38 Adapter |
| 12 Tube assembly | 26 Clamp, grounding | 39 Cap, dust |
| 13 Elbow, male | 27 Ground rod assembly | 40 Washer, spring tension |
| 14 Gasket | | |

Figure 1-1. Schematic flow through system.

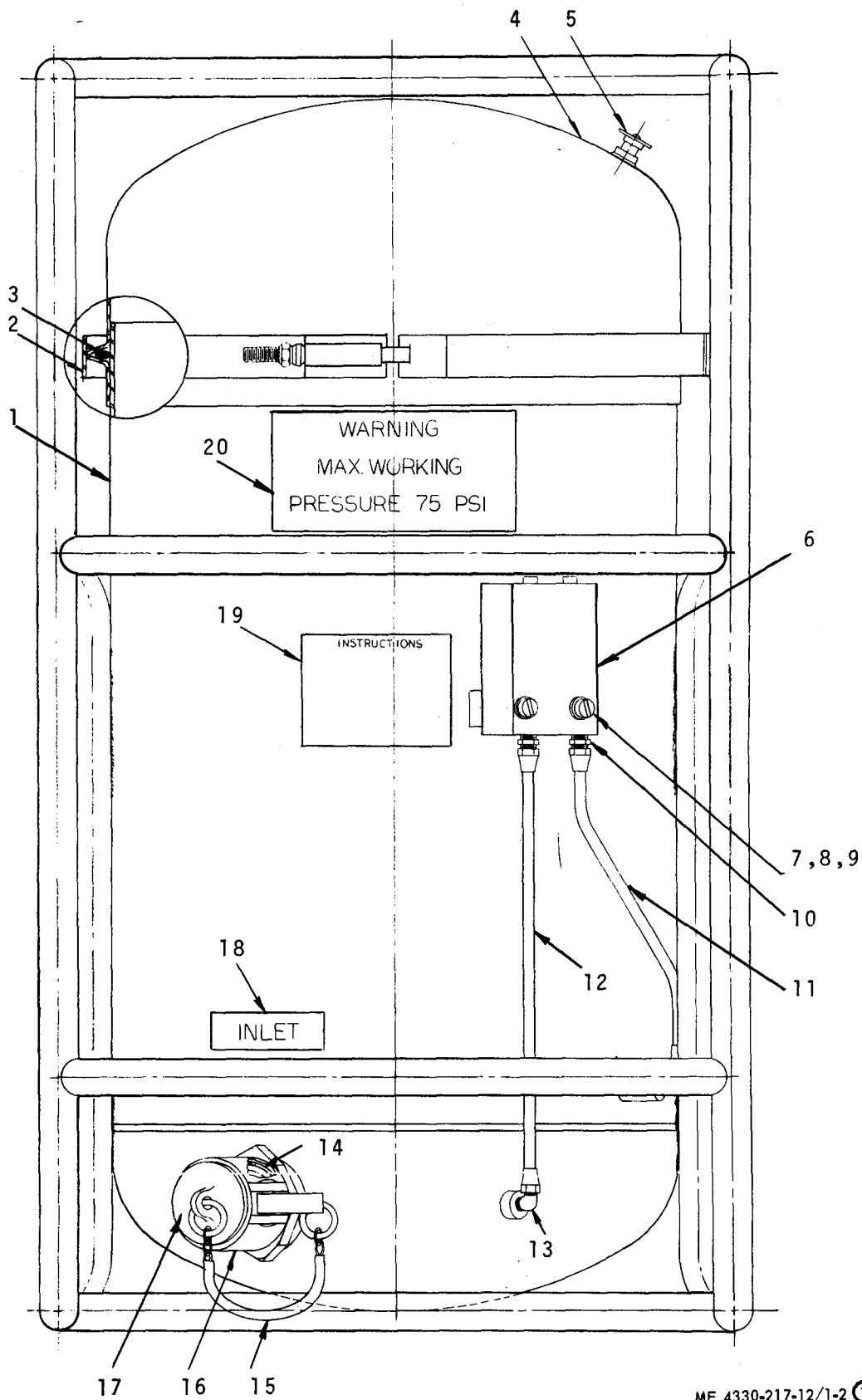

ME 4330-217-12/1-2 ①

Figure 1-2. Liquid filter separator (sheet 1 of 2).

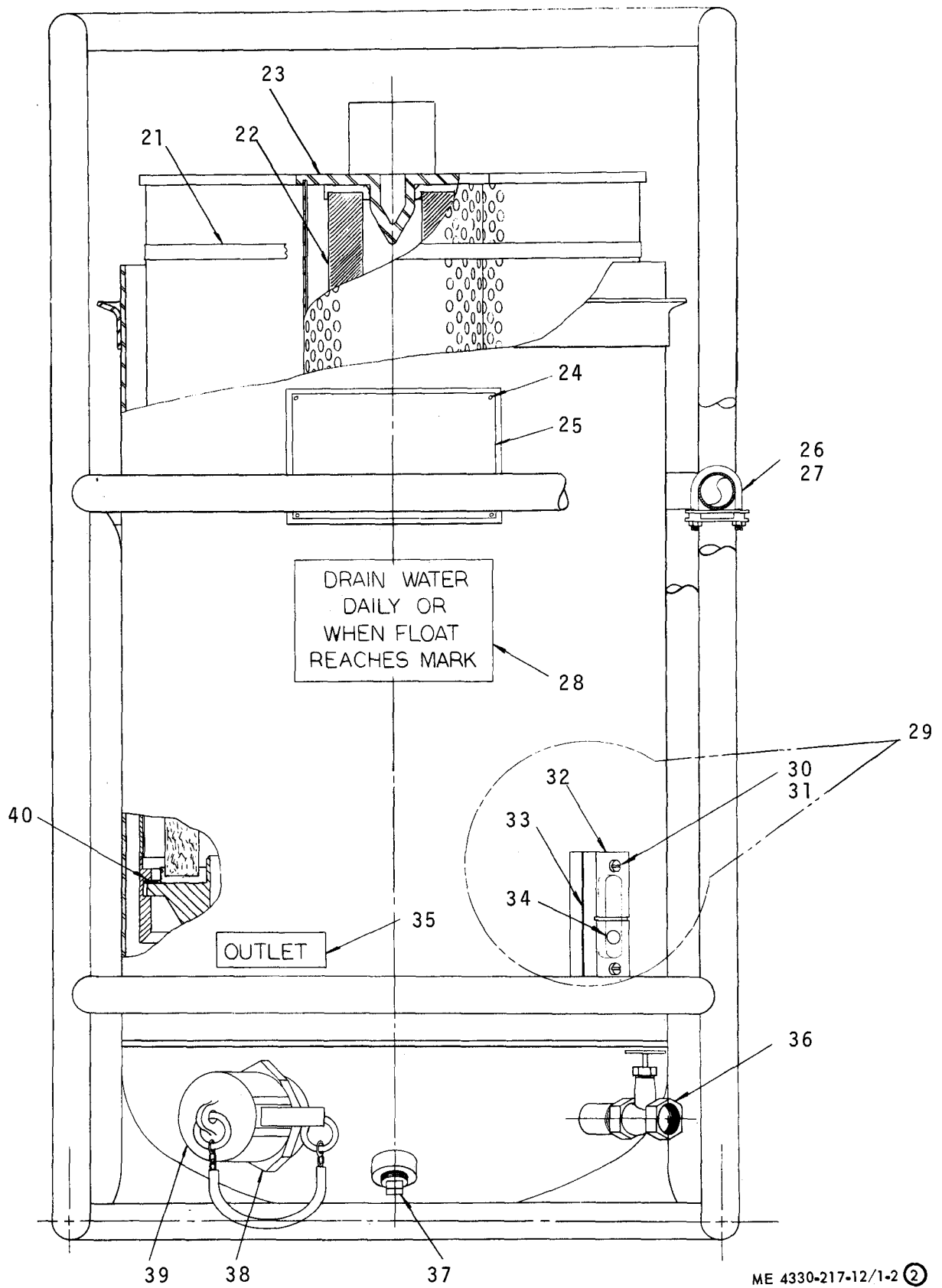

Figure 1-2. Liquid filter separator (sheet 2 of 2).

b. *Detailed Description.* The filter-separator functions in the following manner:

(1) *Filter element.* The filter element consists of a perforated center tube surrounded by a pleated paper tube filtering material, which is in turn wrapped with several layers of fiberglass mats, each of which performs a function in the filtering and coalescing process. Fuel enters the filter through the perforated center tube and passes toward the outside of the element. The function of the pleated paper tube material is to remove solid contaminants from the fuel. Upon reaching the exterior of the pleated paper tube, the fuel with its entrained water passes through the layers of fiberglass, which coalesces the entrained water into large droplets which fall by gravity to the sump upon reaching the element outer surface. The outside wrap of the element is fiberglass screen which supports the element against rupture from high differential pressures.

(1) *Canister.* The canister is a cylindrical device which functions to prevent small water droplet carryover to the effluent stream. The canister is constructed with an outer tube of perforated metal, lined internally with teflon-coated screen, which in turn is protected by an aluminum wire mesh inner screen. The teflon-coated screen allows clean fuel to pass through, while repelling the water droplets to keep them within the canister. One end of the canister is open for water drop-out while the other end has a blank metal cap containing a raised metal boss. This metal boss fits into the element and acts as a seal against by-pass flow. The seal for the other end of the element is a stool attached to the internal deck plate of the vessel.

1-6. Differences Between Models

This manual covers only the model 844-5-V-100AL filter-separator. No known differences exist for the model covered by this manual.

1-7. Identification and Tabulated Data

a. *Identification.* The filter-separator has one identification plate located above the sight gage on the side of the tank. The identification plate specifies military specification number, design activity code number, manufacturer, element quantity, maximum working pressure, weight, Federal stock number, model number, contract number, and date of manufacture.

b. *Tabulated Data.*

(1) *Identification.*

Manufacturer Keene Corp., Fluid Handling
Div.
Model number 844-5-V-100AL
Specification No 52556C
Federal stock no. 4330-491-4957
Contract no DAAK02-72-C-0280

(2) *Description.*

Capacity 100 GPM
Element, quantity 5
Working pressure max 75 PSI
Weight 100 pounds
Date of manufacture 1972

(3) *Elements.*

Part number MIL-F-52308
Federal stock no. 4330-983-0998

(4) *Canisters.*

Part number 13216E2773
Federal stock no. 4330-112-0256

(5) *Differential pressure indicator.*

Part number Dwg. 27N22
Manufacturer Keene Corp., Fluid Handling
Div. (08181)
Federal stock no. 6685-451-3274

OPERATING INSTRUCTIONS

Section I. OPERATING PROCEDURES

WARNING

Do not operate the filter-separator unit until it has been connected to a suitable ground. Ground unit properly by driving grounding rod into ground at least 36 inches before connecting ground cable. In the event that impregnable soil is encountered bury in a horizontal trench not less than eight feet in length and at least eight inches beneath the surface. A static-discharge could ignite the fuel or cause an explosion of the fuel vapor.

2-1. General

a. The instructions in this section are for the information and guidance of personnel responsible for operation of the filter-separator.

b. The operator must know how to perform every operation of which the filter-separator is capable. This section contains instructions on starting, operation, and stopping of the filter separator. Since nearly every installation presents a different problem, the operator may have to vary given procedures to fit the condition. *It is mandatory that the performance of filter-separators on all aircraft refueling equipment be checked every 30 days through the submission of samples taken from the effluent stream of the filter separator.* Upon request, the petroleum representative will furnish sample containers to components of the Army, Army National Guard, or Reserve operating aircraft refueling equipment. Samples will be sent to the petroleum laboratory designated by the petroleum representative. In the event a sample indicates unsatisfactory performance of filter-separator equipment, the submitting activity will be notified by telephone and will be advised to change the filter-separator elements (AR 703-1, 1 Apr. 1971).

2-2. Starting*a. Preparation for Starting*

(1) Make sure that water drain valve (36, fig. 1-2, sheet 2 of 2) is closed.

(2) Be sure hoses are connected securely to inlet and outlet.

(3) Slightly open air vent valve (5 fig. 1-2, sheet 1 of 2) to allow entrapped air to escape.

(4) Start the system pumping unit.

(5) Open any up-stream blocking valve slightly to fill slowly with as little pressure as possible.

(6) When the unit is completely filled, fuel will come through the air vent valve. Close the air vent valve. Make a visual inspection of all connections, joints, and piping components for visible leaks.

b. Operation.

(1) After completion of the visual inspection, open any down-stream system blocking valve to full open position.

(2) Open the up-stream blocking valve.

(3) When the filter-separator is on full operating pressure and flow, check differential pressure indicator (6, fig. 1-2, sheet 1 of 2). If either button has popped up during initial startup, reset buttons and continue operation.

(4) When the filter-separator is in operation, periodic examination of all connections, valves, and gages for possible malfunctions or leaks is recommended.

(5) Check differential pressure indicator periodically. Change filter elements (para 3-5) immediately if the red button on the differential pressure indicator is in a raised position.

(6) Once each day, open the air vent valve (5, fig. 1-2, sheet 1 of 2) slightly during operation to be sure the filter-separator remains free of entrapped air. When all the entrapped air has escaped, a small amount of fuel will come out the air vent valve. At this point close the valve.

(7) Drain water daily or when ball (34, fig. 1-2, sheet 2 of 2) reaches the mark on the body (32) of the sight gage assembly (29).

2-3. Stopping

a. Stop the system pumping unit.

b. Close the up-stream blocking valve.

c. Close the down-stream blocking valve to isolate the filter-separator from the system.

d. Drain any accumulated water by opening water drain valve (36, fig. 1-2, sheet 2 of 2).

2-4. Operation Under Unusual Conditions

a. Operation in Extreme Cold.

(1) The filter-separator is not equipped with winterizing gear. The stopping procedure will be the same as during operation under usual conditions, except water must be drained more frequently than usual and at each shut down by opening the water drain valve (36, fig. 1-2, sheet 2 of 2). If possible provide a heated shelter.

(1) Check differential pressure indicator (6, fig. 1-2, sheet 1 of 2) periodically to be sure that differential setting has not been exceeded. Change filter elements (para 3-5) if necessary.

b. Operation in Dusty or Sandy Areas.

(1) Under dusty or sandy conditions, filter elements must be replaced at more frequent intervals. Select a worksite protected by natural barriers or erect screens of dustproof material.

(2) Keep the unit free of dust and dirt, especially when the unit is open for servicing.

(3) Erect a shelter to prevent dust in the interior of the filter-separator when it is opened for servicing.

(4) Check differential pressure indicator periodically to be sure that pressure setting has not been exceeded.

c. Operation Under Rainy or Humid Conditions.

(1) Rainy or extremely humid conditions may cause unusual amounts of water to be entrained in

the fuel. Water must be drained from the sump through the water drain valve more frequently than under normal conditions.

(2) Erect a shelter to prevent the entrance of rain into the interior of the filter-separator when it is opened for servicing.

(3) Check differential pressure indicator periodically to be sure that pressure setting has not been exceeded.

d. Operation in Salt Water Areas.

(1) To prevent corrosion, wipe or flush down the exterior surfaces of the filter-separator regularly with fresh water. Inspect all painted surfaces for cracked, chipped, peeled, or blistered paint. Coat all exterior exposed surfaces in accordance with Military Specification MIL-T-704, Type A. Color is to be olive-drab, shade 34087 of Federal Standard No. 595.

(1) Check differential pressure indicator periodically to be sure that pressure setting has not been exceeded.

e. Operation in High Altitudes.

(1) The filter-separator is pressurized during normal operation. Operation at high altitudes will not increase internal pressures beyond the normal limits of the equipment.

(2) Check differential pressure indicator periodically to be sure that pressure setting has not been exceeded.

CHAPTER 3

OPERATOR/ CREW MAINTENANCE INSTRUCTIONS

Section I. LUBRICATION INSTRUCTIONS

3-1. Lubrication Instructions

No lubrication is required for the filter-separator.

Section II. PREVENTIVE MAINTENANCE

3-2. General

To insure that the filter-separator is ready for operation at all times, it must be inspected systematically so that defects may be discovered and corrected before they result in serious damage or failure. The preventive maintenance checks and services to be performed are listed and described in table 3-1. The item numbers indicate the sequence of inspection requirements. Defects discovered during operation of the unit will be noted for future correction to be made as soon as operation has

ceased. Stop operation immediately if a deficiency is noted during operation which would damage the equipment if operation were continued. Only those faults that cannot be corrected by the operator or crew, or that are corrected by replacing parts, will be recorded on DA Form 2404.

3-3. Preventive Maintenance Checks and Services

Refer to table 3-1 for the operator's preventive maintenance checks and services.

Table 3-1. Preventive Maintenance Checks and Services

Item No.	Interval				Item to be inspected	Procedure	Reference				
								B-Before operation	D-During operation	A-After operation	W-Weekly
	Daily										
B	D	A	W								
1	X	X	X		Filter-separator	Inspect the filter-separator for all obvious deficiencies such as loose or missing bolts and nuts, and for bent, cracked, warped, or broken parts. Investigate any unusual operation such as erratic vibration, intake, or discharge.					
2	X	X	X		Valves	Check that all manual valves operate freely and that the stems are not bent or broken.					
3		X			Differential pressure indicator	Inspector secure mounting, loose connections, or other damage. Check that button has not popped up indicating that differential setting has been exceeded.	Paragraph 4-14				
4	X	X	X		Body-sight gage	Inspect for leaks, paying particular attention to the connections. Check that indicator ball floats freely.	Paragraph 4-15				
5	X	X	X		Common lines and fittings	Inspect all tubing for kinks, breaks, and loose connections at pressure indicator. Replace or repair all damaged fuel lines and fittings.					
6	X		X		Coupler, adapter, dust caps, and dust plugs.	Inspect gaskets for deterioration, breakage, and loss of resiliency.					

Section III. TROUBLESHOOTING

3-4. General

Table 3-2 provides information useful in diagnosing and correcting troubles which cause unsatisfactory operation or failure of the filter-separator and its components. Each malfunction stated is followed by a list of tests or inspections to

locate or verify the malfunction, followed by corrective action recommended to remedy malfunction. Any trouble beyond the scope of operator maintenance must be reported to organizational maintenance.

Table 3-2. TROUBLESHOOTING

MALFUNCTION, TEST OR INSPECTION	CORRECTIVE ACTION
1. DIRTY FUEL AT NOZZLE.	Inspect for ruptured element. Replace element.
2. NO FUEL DELIVERY	Check to see if inlet or outlet valves are closed. Open valves.
2. GENERAL FUEL LEAKAGE	Step 1. Inspect to see if cover gasket is worn or torn. Replace cover gasket. Step 2. Check for loose hardware or fittings. Tighten hardware or fittings.
4. DISCHARGED FUEL CONTAINS WATER	Step 1. Check to see if teflon coated screen in the canisters is torn or cracked. Replace canisters. Step 2. Inspect for over accumulation of water in sump. Drain water from sump.
5. SUDDEN INCREASE OR DECREASE IN PRESSURE DIFFERENTIAL.	Check for clogged or ruptured filter elements. Replace filter elements.

Section IV. MAINTENANCE OF FILTER-SEPARATOR

WARNING

Fuel resistant rubber gloves must be worn at all times when working with any component that has been soaked or contaminated with fuel. Fuels contain varying amounts of toxic chemicals which, if improperly handled, can result in serious health hazards.

3-5. Element and Canister

a. Safety Precautions.

(1) If a filter-separator has been service for a period of time with leaded fuels, a muddy sludge or sediment may be deposited on the filter elements. This sludge is particularly hazardous because it contains varying amounts of "tetraethyl lead". The toxic effects of this compound or vapor is cumulative and leads to lead poisoning.

(2) Stay on the up-wind side of the filter-

separator being cleaned. Avoid the lead sludge contacting the clothing and skin by not splashing the sludge and by wearing fuel resistant rubber gloves.

(3) Keep the sludge or lead out of the mouth. Do not carry food in the pockets and do not store food near a tank because food will readily absorb lead vapor. Always wash before eating or smoking.

b. *Removal.* Remove the filter elements in the following manner.

(1) Stop the pumping unit. Shut off up-stream and down-stream system valves.

CAUTION

Depressurize the tank before attempting removal of the filter elements. System pressure may be trapped in the tank.

(2) Very slowly open the air vent valve (5, fig.

1-2, sheet 1 of 2) to relieve pressure in the filter-separator. Open the water drain valve (36, fig. 1-2, sheet 2 of 2) and drain tank.

(3) Remove the cover clamp (2, fig. 1-2, sheet 1 of 2), cover gasket (3), and cover (4).

(4) Remove canister clamp band (21, fig. 1-2, sheet 2 of 2).

(5) Turn canisters (23) counterclockwise to release locking action from the unit.

(6) Pull the canisters up and out of the tank.

(7) Remove the elements (22) from the mountings in the tank.

(8) Discard used elements in a safe approved manner.

c. Cleaning. Clean tank and canisters (23, fig. 1-2, sheet 2 of 2) in the following manner.

(1) Interior of tank can be steam cleaned, if available. Sludge can be scraped or scooped from tank with a squeegee or wooden scoop which has all sharp edges rounded off.

(2) Wipe all contamination from the canister using a squeegee. Refer to TM 38-230 for proper methods.

d. Inspection.

(1) Inspect canister for cracks, tears, and rips.

(2) Check that canister is clean.

e. Repair of Canister.

(1) Use thin blade screwdriver to remove spring tension washer as shown on figure 3-1.

CAUTION

Do not allow any metal objects to come into contact with the teflon-coated screen.

(2) Install new washer by placing one end against the boss in the groove and compressing the washer into place.

f. Installation.

(1) Install new filter elements (22, fig. 1-2, sheet 2 of 2) on the mountings in the tank. Install canisters over the elements and turn clockwise for locking action.

(2) Install the canister clamp band (21).

(3) Install cover (4, fig 1-2, sheet 1 of 2), cover gasket (3), and cover clamp (2).

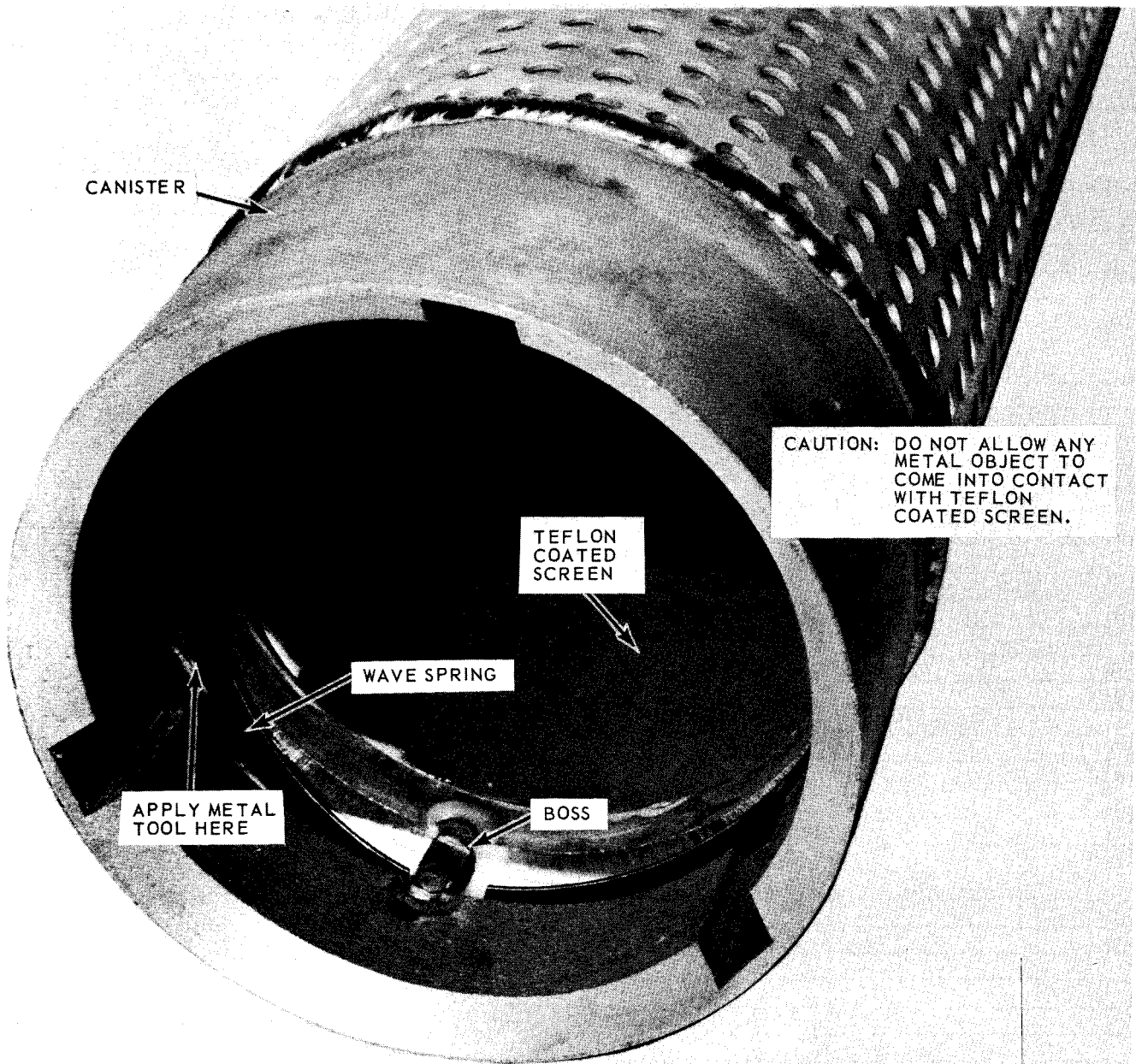

CAUTION: DO NOT ALLOW ANY METAL OBJECT TO COME INTO CONTACT WITH TEFLON COATED SCREEN.

TEFLON COATED SCREEN

WAVE SPRING

APPLY METAL TOOL HERE

BOSS

NOTE: TO REMOVE WAVE SPRING, APPLY METAL TOOL TO OUTSIDE PERIMETER OF SPRING AT NOTCH. PRESS END OF WAVE SPRING TO CENTER AND UP TO CANISTER MOUTH. GRASP WAVE SPRING WITH PLIERS AND PULL INWARD AND OUT.

NOTE: WHEN INSTALLING WAVE SPRING, PLACE ONE END AGAINST BOSS IN GROOVE AND COMPRESS SPRING INTO PLACE.

ME 4330-217-12/3-1

Figure 3-1. Spring tension washer (wave spring) removal and installation.

ORGANIZATIONAL MAINTENANCE INSTRUCTIONS

Section I. SERVICE UPON RECEIPT OF MATERIAL

4-1. Inspecting and Servicing the Equipment

Perform a careful and thorough visual inspection of the following areas:

- a.* Inspect air vent valve for damage.
- b.* Inspect sight gage for damage.
- c.* Inspect all valves, piping, and fittings for loose connections and/or damage.

4-2. Installation

a. Select an installation site which will enable the filter-separator to be properly installed into the system.

b. In placing the filter-separator in the system (fig. 4-1) keep it as level as possible to ensure proper operation.

c. Run water drain hose away from unit so that water does not accumulate around filter-separator.

String out hose to a trench to collect the water. There can be some traces of fuel in the water discharge due to vortexing or overdraining.

d. Make sure that inlet and outlet hoses are properly connected and securely attached, free of leaks, and not kinked.

e. Remove the cover (4, fig. 1-2, sheet 1 of 2) by removing the cover clamp (2) and cover gasket (3).

f. Check visually to be sure canisters (23, fig. 1-2, sheet 2 of 2) are in place. Reinstall cover.

g. Ground the unit by driving ground rod at least 36 inches into ground before connecting ground cable. In event that impregnable soil is encountered, bury rod in a horizontal trench not less than 8 feet long and at least 8 inches beneath the surface.

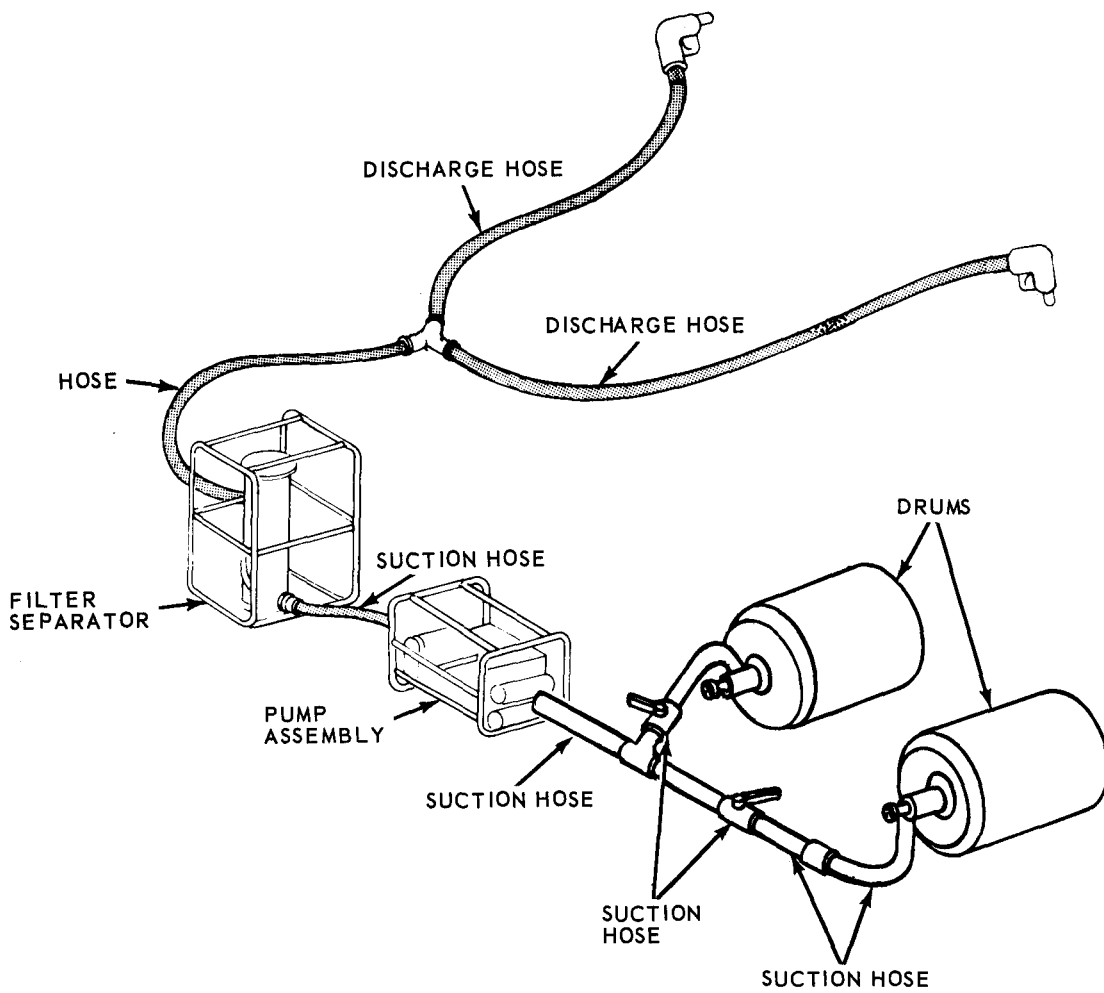

ME 4330-217-12/4-1

Figure 4-1. Typical installation.

Section II. MOVEMENT TO A NEW WORK SITE

4-3. Dismantling for Movement

- a. Disconnect the inlet and discharge hoses. Drain them of residual fuel.
- b. Open the air vent valve (5, fig. 1-2, sheet 1 of 2) at the top of the filter-separator.
- c. Open the water drain valve (36, fig. 1-2, sheet 2 of 2) to drain water and fuel from the filter-separator.

- d. Close the air vent valve and the water drain valve after draining is complete.

4-4. Reinstallation After Movement

Inspect, service and install the filter-separator as instructed in paragraphs 4-1 and 4-2.

Section III. REPAIR PARTS, SPECIAL TOOLS, AND EQUIPMENT

4-5. Tools and Equipment

There are no tools or equipment issued with the filter-separator.

4-6. Special Tools and Equipment

No special tools and equipment are required by

organizational maintenance personnel for performing maintenance on the filter-separator.

4-7. Maintenance Repair Parts

Appendix C of this manual lists repair parts authorized for organizational maintenance.

Section IV. PREVENTIVE MAINTENANCE CHECKS AND SERVICES

4-8. General

To insure that the filter-separator is ready for operation at all times, it must be inspected systematically so that defects may be discovered and corrected before they result in serious damage or failure. The preventive maintenance checks and services to be performed are listed as described in table 4-1. All deficiencies and shortcomings will be

recorded, together with corrective action taken, on DA Form 2404.

4-9. Preventive Maintenance Checks and Services

Refer to table 4-1 and perform preventive maintenance checks and services in accordance with number sequence.

Table 4-1. PREVENTIVE MAINTENANCE CHECKS AND SERVICES

Item No.	Interval Org.		M—Monthly	Q-Quarterly	Reference
	M	Q	Item to be inspected	Procedure	
1		1	Water Level Sight Gage	Inspect body of sight gage for breaks and cracks, replace defective sight gage or gasket.	Paragraph 4-14
2		2	Valves, lines and fittings	Inspect for loose fittings, broken or crimped lines. Check operation of water drain cock and air vent valve.	Paragraph 4-17 and 4-18
3		3	Tank	Inspect tank for rust, clean and paint exposed surfaces.	

Section V. TROUBLESHOOTING

4-10. General

This section provides information useful in diagnosing and correcting unsatisfactory operation or failure of the filter-separator and its components. Malfunctions which may occur are listed in table 4-

2. Each malfunction stated is followed by a list of tests or inspections to locate or verify the malfunction, followed by the corrective action recommended to remedy the malfunction.

Table 4-2. TROUBLESHOOTING

MALFUNCTION	TEST OR INSPECTION	CORRECTIVE ACTION
1. YELLOW BUTTON ON DIFFERENTIAL PRESSURE INDICATOR POPS UP.		Inspect elements as they may be contaminated. Replace elements:
2. RED BUTTON ON DIFFERENTIAL PRESSURE INDICATOR POPS UP.		Step 1. Check inlet and outlet for clogged condition. Clean inlet and outlet pipes. Step 2. Inspect differential pressure lines for leaking or frozen condition. Repair or replace lines (para 4-15). Step 3. Inspect differential pressure indicator for defective condition. Test differential pressure indicator and replace (para 4-16). Step 4. Inspect filter elements for dirty, ruptured, or clogged condition. Replace filter elements.

Section VI. MAINTENANCE OF VALVES, LINES, AND FITTINGS

4-11. General

The valves, lines, and fittings include the two differential pressure indicator lines, the water drain valve and drain line, the inlet coupler and outlet adapter, and the air vent valve.

4-12. Water Drain Valve

a. Removal. Remove the water drain valve (36, fig. 1-2, sheet 2 of 2) in the following manner.

(1) Stop pumping unit. Shut off up-stream and down-stream system valves.

CAUTION

Depressurize the tank before attempting removal of the water drain valve.

(2) Slowly open the air vent valve (5, fig. 1-2, sheet 1 of 2) to relieve pressure in filter-separator. Open water drain valve (36, fig. 1-2, sheet 2 of 2) and drain tank.

(3) Unscrew water drain valve from tank.

b. Cleaning.

(1) Remove all dust, dirt, and film from all parts with a brush.

(2) Clean all metal parts in cleaning solvent and dry thoroughly. Refer to TM 38-230.

c. Inspection of Water Drain Valve.

(1) Examine all threaded areas for thread damage.

(2) Inspect water drain valve for mechanical damage.

d. Installation of Water Drain Valve.

(1) Install water drain valve into tank. Apply sealing compound MIL-S-7916 to all threaded fittings. Tighten securely.

(2) Start up operation of filter-separator as described in paragraph 2-2.

Section VII. MAINTENANCE OF WATER-LEVEL SIGHT GAGE AND DIFFERENTIAL PRESSURE INDICATOR

4-13. General

a. The water-level sight gage consists of a float ball in a plastic body to indicate the level of water in the bottom of the filter-separator tank.

b. The differential pressure indicator is controlled by pressure supplied through two lines. One line supplies pressure from below the filter-separator tank baffle. The other line supplies

pressure from above the tank baffle. When the pressure differential equals or exceeds 20 psi, the yellow button on the differential pressure indicator “pops up”. When the pressure differential equals or exceeds 3.5 psi, the red button “pops up”.

4-14. Sight Gage

a. Removal. Remove the sight gage assembly (29, fig. 1-2, sheet 2 of 2) in the following manner.

(1) Stop the pumping unit. Shut off up-stream and down-stream system valves.

CAUTION

Filter-separator tank must be isolated from the fuel system and depressurized before attempting removal of the sight gage.

(2) Very slowly open air vent valve (5, fig. 1-2, sheet 1 of 2) to relieve pressure in filter-separator. Open water drain valve (36, fig. 1-2, sheet 2 of 2) and drain tank.

(3). Remove screws (30), washer (31), and remove sight gage body (32) and ball (34). Remove and discard gasket (33).

b. Cleaning. Remove all dust, dirt, and film from sight gage with a soft bristle brush, being careful not to damage the gage.

c. Inspection of Sight Gage. Inspect gage for cracks, nicks, or other damage. Replace sight gage if necessary.

d. Installation. Install sight gage in the following manner.

(1) Install new gasket (33). Apply silicone compound MIL-S-8660.

(2) Place ball (34) into sight gage body (32).

(3) Install sight gage body (32) to tank with washers (31) and screws (30).

(4) Start up operation of filter-separator as described in paragraph 2-2.

4-15. Differential Pressure Indicator

a. Removal. Remove the differential pressure indicator (6, fig. 1-2, sheet 1 of 2) in the following manner.

(1) Stop pumping unit. Shut off up-stream and down-stream system valves.

CAUTION

Depressurize the tank before attempting removal of the differential pressure indicator.

(2) Slowly open air vent valve (5) to relieve pressure in filter-separator. Open water drain valve (36, fig. 1-2, sheet 2 of 2) and drain tank.

(3) Disconnect coupling nuts (4, fig. 4-2) from elbows (1) and connectors (6). Remove tubing (2 and 3). Remove elbows and connectors if damaged. Remove screws (8) and washers (9 and 10) to remove differential pressure indicator (7).

Key to figure 4-2:

- 1 Elbow
- 2 Tubing assembly
- 3 Tubing assembly
- 4 Nut, coupling
- 5 Tubing
- 6 Connector, male
- 7 Differential pressure indicator
- 8 Screw, machine
- 9 Washer, flat
- 10 Washer, lock

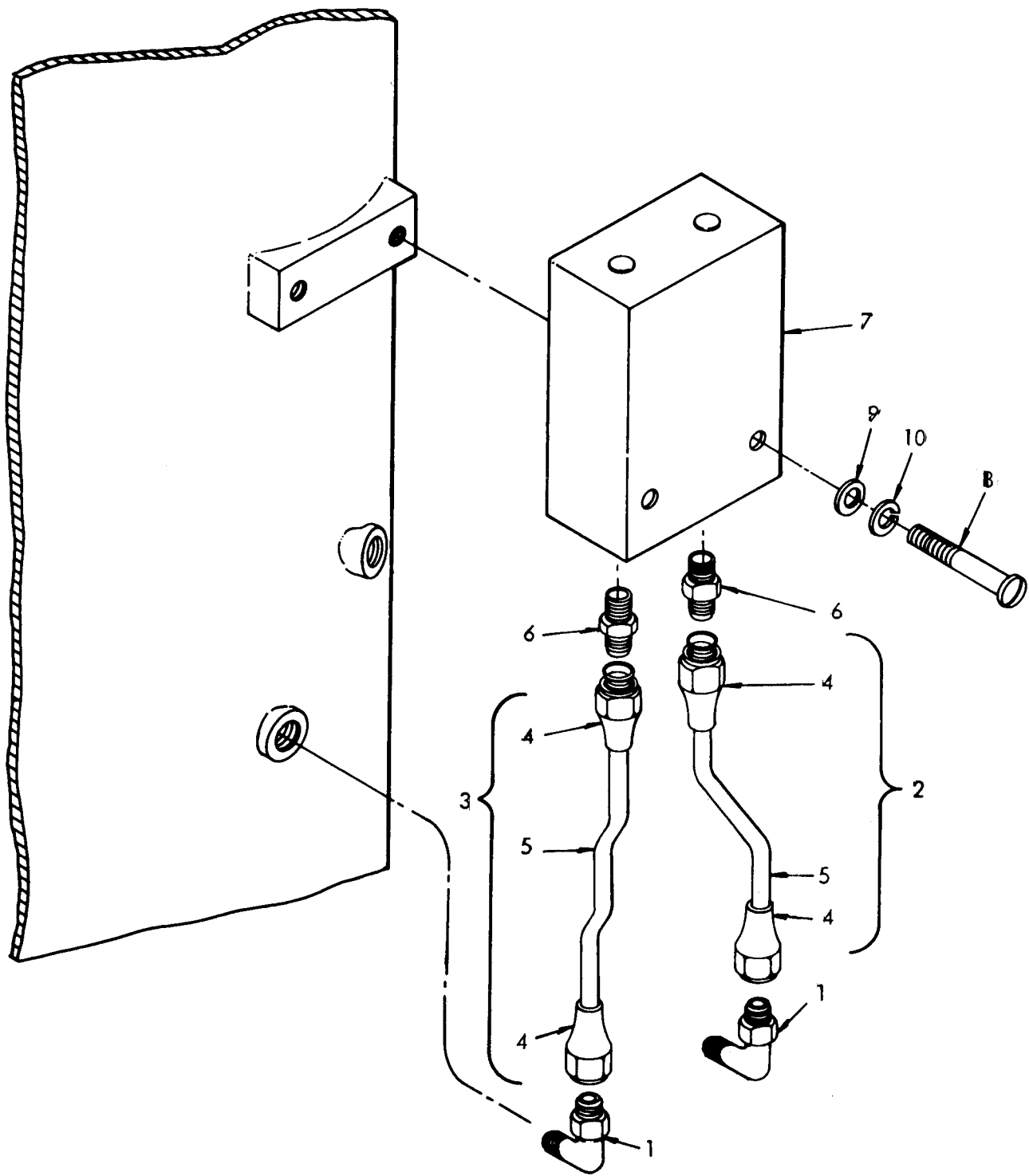

ME 4330-217-12/4-2

Figure 4-2. Differential pressure indicator.

b. Inspection.

(1) Inspect all parts for cracks, breaks, and other damage.

(2) Examine all threaded areas for thread damage. Replace all defective parts.

(3) Inspect differential pressure indicator for mechanical damage. Replace entire unit if defective.

c. Installation.

(1) Install differential pressure indicator (7), to tank with washers (9 and 10), and screw (8), elbows (1), and connectors (6) if removed.

(2) Connect the tube assemblies (2 and 3) by tightening the fitting nut (4) to elbows (1) and connectors (6). Apply sealing compound MIL-S 7916 to all threaded fittings.

(3) Start up operation of filter-separator as described in paragraph 2-2.

4-16. Testing, Inspection, and Replacement

a. The differential pressure indicator may be

tested by supplying an equal-gauged pressure of 50 PSI to each of the ports, then increasing the pressure at the high pressure inlet port until the buttons "pop up". The difference between the two pressure readings should be 20 PSI \pm 15% for the yellow button and 35 PSI \pm 15% for the red button. Replace the differential pressure indicator if it is inoperative or not within tolerance.

b. When required to test the effectiveness of filtration, and consequently proper operation of the pop-up button indicators, submit a sample of the product from the down-stream side of the filter-separator to the nearest petroleum laboratory. Whenever this is accomplished, ensure that the sample container is clean. Record dates samples are submitted and record test results for the filter separator. Refer to TM 10-1101. If test results show that the solids contents of samples exceeds 2.0 MG/L, replace filter elements.

Section VIII. MAINTENANCE OF TANK AND FRAME ASSEMBLY

4-17. General

The tank and frame assembly is of welded aluminum alloy construction.

4-18. Tank and Frame Assembly

a. Cleaning, Inspection, and Repair.

(1) Refer to paragraphs 3-5 *b*, 4-12 *a*, 4-15 *a* and remove filter-separator components as necessary to facilitate repair.

(2) Open water drain valve (36, fig. 1-2, sheet 2 of 2) and remove pipe plug (37) to completely drain tank prior to welding.

(3) Refer to figure 1-2, sheets 1 and 2. All data plates except the identification plate are attached to the tank with adhesive and should not be removed.

(4) Clean metal parts in cleaning solvent and dry thoroughly. Refer to TM 38-230.

(5) Inspect tank for bends, cracks, and broken welds.

(6) Straighten and weld frame as required.

(7) Spot paint or repaint equipment as necessary with paint in accordance with MIL-T-704, Type C, color 34087.

b. Installation. Install components that were removed by referring to paragraphs 3-5 *f*, 4-12 *d*, 4-14 *d*, and 4-15 *c* as applicable. Install pipe plug (37, fig. 1-2, sheet 2 of 2), apply sealing compound MIL-S-7916 for threads.

APPENDIX A

REFERENCES

A-1. Fire Protection

TB 5-4200-200-10

Hand Portable Fire Extinguishers Approved for Army Users

A-2. Painting

AR 740-1

Color, Marking, and Preparation of Equipment for Shipment

AR 746-5

Color and Marking of Army Material

A-3. Shipment and Storage

TB 740-97-2

Preservation of USAMEC Mechanical Equipment for
Shipment and Storage

TB 740-90-1

Administrative Storage of USAMEC Equipment

MIL-F-52556

Packaging of Fuel Filter-Separators

A-4. Demolition

TM 750-244-3

Destruction of Material to Prevent Enemy Use

A-5. Cleaning

TM 38-230

Cleaning of Fuel Contaminated Surfaces

A-6. Maintenance

TM 38-750

The Army Maintenance Management System

APPENDIX B

MAINTENANCE ALLOCATION CHART

Section I. INTRODUCTION

B-1. General

a. This section provides a general explanation of all maintenance and repair functions authorized at various maintenance levels.

b. *Section II*, designates overall responsibility for the performance of maintenance functions on the identified end item or component. The implementation of the maintenance functions upon the identified end item or component will be consistent with the assigned maintenance functions.

c. *Section III*, lists the special tools and test equipment required for each maintenance function as referenced from *Section II*. (Not applicable).

d. *Section IV*, contains supplemental instructions or explanatory notes required for a particular maintenance function.

B-2. Explanation of Columns in Section II.

a. *Group Number, Column (1)*. The assembly group number is a numerical group assigned to each assembly. The assembly groups are listed on the MAC in disassembly sequence beginning with the first assembly removed in a top down disassembly sequence.

b. *Assembly Group, Column (2)*. This column contains a brief description of the components of each assembly group.

c. *Maintenance Functions, Column (3)*. This column lists the various maintenance functions (A through K). The upper case letter placed in the appropriate column indicates the lowest maintenance level authorized to perform these functions. The active repair time required to perform the maintenance function is included directly below the symbol identifying the category of maintenance. The symbol designations for the various maintenance levels are as follows:

- C-Operator or crew
- O-Organizational maintenance
- F-Direct support maintenance
- H-General support maintenance
- D-DePot maintenance

The maintenance functions are defined as follows:

A-Inspect. To determine serviceability of an item by comparing its physical, mechanical, and electrical characteristics with established standards.

B-Test. To verify serviceability and to detect electrical or mechanical failure by use of test equipment.

C-Service. To clean, to preserve, to charge, and to add fuel, lubricants, cooling agents, and air.

D-Adjust. To rectify to the extent necessary to bring into proper operating range.

E-Align. To adjust specified variable elements of an item to bring to optimum performance.

F-Calibrate. To determine the corrections to be made in the readings of instruments or test equipment used in precise measurement. Consists of the comparison of two instruments, one of which is a certified standard of known accuracy, to detect and adjust any discrepancy in the accuracy of the instrument being compared with the certified standard.

G-Install. To set up for use in an operational environment such as an emplacement, site, or vehicle.

H-Replace. To replace unserviceable items with serviceable like items.

I-Repair. Those maintenance operations necessary to restore an item to serviceable condition through correction of material damage or a specific failure. Repair may be accomplished at each level of maintenance.

J-Overhaul. Normally, the highest degree of maintenance performed by the Army in order to minimize time work is in process consistent with quality and economy of operation. It consists of that maintenance necessary to restore an item to completely serviceable condition as prescribed by maintenance standards in technical publications for each item of equipment. Overhaul normally does not return an item to like new, zero mileage, or zero hour condition..

K-Rebuild. The highest degree of material maintenance. It consists of restoring equipment as nearly as possible to new condition in accordance with original manufacturing standards. Rebuild is performed only when required by operational considerations or other paramount factors and then only at the depot maintenance level. Rebuild reduces to zero the hours or miles the equipment, or component thereof, has been in use.

The maintenance functions are defined as follows:

d. *Tools and Equipment, Column (4)*. This column not applicable.

e. *Remarks, Column (5)*. This column is provided for referencing by code the remarks (sec. IV) pertinent to the maintenance functions.

B-3. Explanation of Columns in Section III. (Not applicable).

B-4. Explanation of Columns in Section IV.

a. *Reference Code*. This column consists of two letters separated by a dash (entered from column 5 of sec. II). The first letter references alpha sequence in column 5 and the second letter references a maintenance function, column 3, A through K.

b. *Remarks*. This column lists information pertinent to the maintenance function to be performed (as indicated in sec. II).

Section II. MAINTENANCE ALLOCATION CHART

(1) Group No.	(2) Assembly group	(3) Maintenance functions										(4) Tools and equipment	(5) Remarks	
		A	B	C	D	E	F	G	H	I	J			K
		Inspect	Test	Service	Adjust	Align	Calibrate	Install	Replace	Repair	Overhaul			Rebuild
01	COVER, CANISTERS AND ELEMENTS													
	Cover Clamp and Tank Cover	C	C					
	0.1	0.3					
	Canisters and Band	C	..	C	C	O	A-C, B-I
02	Cover Gasket and Elements	C	C					
	0.1	0.3					
	VALVES, LINES AND FITTINGS													
	Water Drain Valve	C	O					
03	0.1	0.3					
	Air Vent Valve	C	O					
	0.1	0.3					
	Lines and Fittings.	C	O					
04	0.1	0.5					
	Coupler and Adapter	C	O					
	0.3	0.8					
	SIGHT GAGE AND DIFFERENTIAL PRESSURE INDICATOR													
05	Sight Gage Water Level	O	O					
	0.1	0.5					
	Differential Pressure	C	O	O					
	Indicator.	0.1	0.8	1.0					
06	TANK AND FRAME ASSEMBLY													
	Tank and Frame.	C	O	O	C-I
	0.5	1.0	3.0				
	Rod Ground Assembly	C	O					
07	0.3	1.0					
	Data Instructions and	C	O					
	Warning Plates	0.1	1.0					

Section IV. REMARKS

Reference Code

Remarks

- A-C Service consists of cleaning of the canister with solvent at each element change.
- B-I Repair consists of replacing the canisters and spring tension washers.
- C-I Repair includes straightening and welding of the frame by experienced alum inure welder.

APPENDIX C

ITEMS TROOP INSTALLED OR AUTHORIZED LIST AND ORGANIZATIONAL MAINTENANCE REPAIR PARTS AND SPECIAL TOOLS LISTS

Section I. INTRODUCTION

C-1. Scope

a. This appendix list repair parts, special tools, test, and support equipment required for the performance of organizational maintenance of the Liquid Fuel Filter-Separator.

b. Repair parts listed represent those authorized for use at the organizational level and will be requisitioned on an "as required" basis until stockage is justified by demand in accordance with AR 710-2.

C-2. General

This Repair Parts and Special Tools List is divided into the following sections:

a. *Items Troop Installed or Authorized List-Section II.* A list in alphabetical sequence, of items which, at the discretion of the unit commander, may accompany the end item, but are not subject to be turned in with the end item.

b. *Repair Parts List-Section III.* A list of repair parts authorized at the organizational level for the performance of maintenance. The list also includes parts which must be removed for replacement of the authorized parts. Parts lists are composed of assembly groups in ascending numerical sequence, with the parts in each group listed in figure and item number sequence.

c. *Special Tools List-Section IV.* (Not applicable).

d. *Federal Stock Number and Reference Number Index-Section V.* A list in ascending numerical sequence, of all Federal stock numbers appearing in the listings followed by a list, in alphanumeric sequence, of all reference numbers appearing in the listings. Federal stock number and reference numbers are cross-referenced to each illustration figure and/or item number.

C-3. Explanation of Columns

The following provides an explanation of columns found in the tabular lists in sections III and V.

a. *Source, Maintenance, and Recoverability Codes (STIR):*

(1) Source code indicates the source for the listed items. Source codes are:

<i>Code</i>	<i>Explanation</i>
P	Repair parts, special tools, and test equipment supplied from GSA/DSA, or Army supply system and authorized for use at indicated maintenance levels.
P2	Repair parts, special tools, and test equipment which are procured and stocked for insurance purposes because combat or military essentiality of the end item dicates that a minimum quantity be available in the supply system.
P9	Assigned to items which are NSA design controlled: unique repair parts, special tools, test, measuring, and diagnostic equipment which are stocked and supplied by the Army COMSEC Logistic System and which are not subject to the provisions of AR 380-41.
P10	Assigned to items which are NSA design controlled: special tools, test, measuring, and diagnostic equipment for COMSEC support which are accountable under the provisions of AR 380-41 and which are stocked and supplied by the Army COMSEC Logistic System.
M	Repair parts, special tools, and test equipment which are not procured or stocked as such in the supply system but are to be manufactured at indicated maintenance levels.
A	Assemblies which are not procured or stocked as such, but are made up of two or more units. Such component units its carry individual stock numbers and descriptions, are procured and stocked separately, and can be assembled to form the required assembly at indicated maintenance levels.
X	Parts and assemblies that are not procured or stocked because the failure rate is normally below that of the applicable end item or component. The failure of such part or assembly should result in retirement of the end item from the supply system.
X1	Repair parts which are not procured or stocked. The requirement for such items will be filled by the next higher assembly or component.
X2	Repair parts, special tools, and test equipment which are not stocked and have no foreseen mortality. The indicated maintenance level requiring such repair parts will attempt to obtain the parts through cannibalization or salvage. The item may be requisitioned with exception data, from the end item manager for immediate use.
G	Major assemblies that are procured with PEMA funds for initial issue only as exchange assemblies at DS and GS level. Those assemblies will not be stocked above the DS and GS level or returned to depot supply level.

NOTE

Cannibalization or salvage may be used as a source of supply for any items source coded above except those coded X 1 and aircraft support items as restricted by AR 700-42.

(2) Maintenance code indicates the lowest level of maintenance authorized to install the repair part and/or use the special tool or test equipment for each application. Capabilities of higher maintenance levels are considered equal or better. Maintenance codes are:

Code	Explanation
C	Crew / Operator
O	Organizational maintenance

(3) Recoverability code indicates whether unserviceable items should be returned for recovery or salvage. Items not coded are nonrecoverable. Recoverability codes are:

Code	Explanation
R	Repair parts (assemblies and components), special tools, and test equipment which are considered economically repairable at direct and general support maintenance levels. When the item is no longer economically repairable, it is normally disposed of at the GS level. When supply considerations dictate, some of these repair parts may be listed for automatic return to supply for depot level repair as set forth in AR 710-50. When so listed, they will be replaced by supply on an exchange basis.
S	Repair parts, special tools, test equipment, and assemblies which are economically repairable at DS and GS activities and which normally are furnished by supply on an exchange basis. When items are determined by a GS to be economically repairable, they will be evacuated to a depot for evaluation and analysis before final disposition.
T	High dollar value recoverable repair parts, special tools, and test equipment which are subject to special handling and are issued on an exchange basis. Such items will be repaired or overhauled at depot maintenance activities only. No repair may be accomplished at lower levels.
U	Repair parts, special tools, and test equipment specifically selected for salvage by reclamation units because of their precious metal content, critical materials, high dollar value, or reusable casings or castings.

b. Federal Stock Number. Indicates the Federal stock number assigned to the item and will be used for requisitioning purposes.

c. Description. Indicates the Federal item name and a minimum description required to identify the item. The last line indicates the reference number followed by the applicable Federal Supply Code for Manufacturer (FSCM) in parentheses. The FSCM is used as an element in item identification to designate manufacturer or distributor or Government agency, etc., and is identified in SB 708-42. Items that are included in kits and sets are listed below the name of the kit or set with quantity of

each item in the kit or set indicated in front of the item name.

d. Unit of Measure (U/M). Indicates the standard or basic quantity by which the listed item is used in performing the actual maintenance function. This measure is expressed by a two-character alphabetical abbreviation, e.g., ea, in., pr etc., and is the basis used to indicate quantities and allowances in subsequent columns.

e. Quantity Incorporated in Unit. Indicates the quantity of the item used in the breakout shown on the illustration figure, which is prepared for an assembly group or an assembly. A "V" appearing in this column in lieu of a quantity indicates that no specific quantity is applicable, e.g., shims, spacers, etc.

f. Fifteen-Day Organizational Maintenance Allowances.

(1) Items authorized for use as required but not for initial stockage are identified with an asterisk in the allowance column.

(2) The allowance columns are divided into four subcolumns. Indicated in each subcolumn is the total quantity of special tools authorized for the number of equipments supported. (Not applicable).

g. Illustration. This column is divided as follows :

(1) *Figure number.* Indicates the figure number of the illustration in which the item is shown.

(2) *Item number.* Indicates the callout number used to reference the item on the illustration.

C-4. Special Information

a. The basis of issue for authorized special tools, test, and support equipment is the number of end items of equipment supported and the number of maintenance personnel allocated to perform the required maintenance operations.

b. Parts which require manufacture or assembly at a level higher than that authorized for installation will indicate in the source column the higher level.

C-5. How to Locate Repair Parts

a. When Federal stock number or reference number is unknown:

(1) Using the table of contents, determine the assembly group within which the repair part belongs. This is necessary since illustrations are prepared for assembly groups, and listings are divided into the same groups.

(2) Find the illustration covering the assembly group to which the repair part belongs.

(3) Identify the repair part on the illustration

and note the illustration figure and item number of the repair part.

(4) Using the repair parts listing, find the assembly group to which the repair part belongs and locate the illustration figure and item number noted on the illustration.

b. When the Federal stock number or reference number is known:

(1) Using the Index of Federal Stock Numbers and Reference Numbers find the pertinent Federal Stock Number or reference number. This index is in ascending FSN sequence followed

by a list of reference numbers in ascending alphanumeric sequence, cross-referenced to the illustration figure number and item number.

(2) Using the repair parts listing, find the assembly, group of the repair part and the illustration figure number and item number referenced in the Index of Federal Stock Numbers and Reference Numbers.

C-6. Abbreviations

- NPT National pipe thread
- UNC Unified National Coarse
- UNF Unified National Fine

Section II. ITEMS TROOP INSTALLED OR AUTHORIZED LIST

(1) SMR CODE	(2) FEDERAL STOCK NUMBER	(3) DESCRIPTION REF NO. & MFG CODE	(4) UNIT OF MEAS.	(5) QTY AUTH
	7520-559-9618	CASE, MAINTENANCE AND OPERATION MANUALS	EA	1

(1) SMR CODE	(2) FEDERAL STOCK NUMBER	(3) DESCRIPTION REF NUMBER & MFR CODE	(4) USABLE ON CODE	(5) UNIT OF MEAS	(5) QTY INC IN UNIT	(6) 15-DAY ORGANIZATIONAL MAINTENANCE ALW				(7) ILLUS- TRATION	
						(a)	(b)	(c)	(d)	(a)	(b)
						1-5	6-20	21-50	51-100	FIG. NO.	ITEM NO.
		SECTION III - REPAIR PARTS FOR ORGANIZATIONAL MAINTENANCE									
		GROUP 01 - COVER, CANISTER									
P20		CLAMP, COVER (49M17) 13217E5356 (97403)		EA	1	*	*	*	*	1-2	2
P O		GASKET, COVER (49M23) SB71587E5M1LR3065 (81349)		EA	1	*	*	*	*	1-2	3
P20		COVER ASSEMBLY (49M08) 13217E5354 (97403)		EA	1	*	*	*	*	1-2	4
P20		CLAMP, CANISTER BAND (49M18) 13216E2789-5 (97403)		EA	1	*	*	*	*	1-2	21
P O	4330-983-0998	ELEMENT (600343) MIL-F-52308 (81349)		EA	5	*	*	*	*	1-2	22
P O	4330-112-0256	CANISTER ASSEMBLY (27M06) 13216E2773 (97403)		EA	5	*	*	*	*	1-2	23
P O	5310-492-2143	WASHER, SPRING TENSION (27M93) 13216E2774 (97403)		EA	5	*	*	*	*	1-2	40
		GROUP 02 - VALVES, LINES AND FITTINGS									
P20	4820-407-2581	VALVE, AIR VENT (16811) 13216E2798 (97403)		EA	1	*	*	*	*	1-2	5
P O	4730-196-9585	CONNECTOR, MALE (19237) AN816-5-AD (88044)		EA	2	*	*	*	*	1-2	10
P O		TUBE ASSEMBLY (49M40) (49M35) 13217E5365-2 (97403)		EA	2	*	*	*	*	1-2	11 12
P O	4730-278-4684	ELBOW, MALE (19236) MS20822-5-AD (96906)		EA	2	*	*	*	*	1-2	13
P O	5330-612-2414	GASKET, COUPLING (49M22) MS27030-6 (96906)		EA	2	*	*	*	*	1-2	14
P20	4730-649-9103	COUPLER (300695) MS27024-11 (96906)		EA	1	*	*	*	*	1-2	16
P20	4730-915-5127	PLUG, DUST (300635) MS27029-11 (96906)		EA	1	*	*	*	*	1-2	17
P O	4820-263-9119	VALVE, WATER DRAIN (49M15) WAV54 (81348)		EA	1	*	*	*	*	1-2	36
P20	4730-079-1362	ADAPTER (300705) MS27020-11 (96906)		EA	1	*	*	*	*	1-2	38
P20	5340-823-5318	CAP, DUST (300645) MS27028-11 (96906)		EA	1	*	*	*	*	1-2	39

(1) SMR CODE	(2) FEDERAL STOCK NUMBER	(3) DESCRIPTION REF NUMBER & MFR CODE	(4) USABLE ON CODE	(5) UNIT OF MEAS	(6) QTY INC IN UNIT	(6) 15-DAY ORGANIZATIONAL MAINTENANCE ALW				(7) ILLUS- TRATION	
						(a)	(b)	(c)	(d)	(a)	(b)
						1-5	6-20	21-50	51-100	FIG. NO.	ITEM NO.
		GROUP 03 - SIGHT GAGE AND DIFFERENTIAL PRESSURE INDICATOR									
P O	6685-451-3274	DIFFERENTIAL PRESSURE INDICATOR ASSEMBLY (27N22) 13218E8895-2 (97403)		EA	1	*	*	*	*	1-2	6
P O	5305-071-2089	SCREW, MACHINE (27N48) MS51957-89 (96906)		EA	2	*	*	*	*	1-2	7
P O	5310-167-0835	WASHER, FLAT 922783) AN960416L (88044)		EA	2	*	*	*	*	1-2	8
P O	5310-582-5965	WASHER, LOCK (300122) MS35338-44 (96906)		EA	2	*	*	*	*	1-2	9
P O	6680-197-4941	SIGHT GAGE ASSEMBLY (49M38) 13217E5360 (97403)		EA	1	*	*	*	*	1-2	29
P O	5305-071-2088	SCREW, MACHINE (24452) MS51957-85 (96906)		EA	2	*	*	*	*	1-2	30
P O	5310-582-5677	WASHER, FLAT (300161) MS15795-810 (96906)		EA	2	*	*	*	*	1-2	31
X		BODY, SIGHT GAGE (47M41) 13217E5361 (97403)		EA	1	*	*	*	*	1-2	32
P O	5330-235-4716	GASKET, SIGHT GAGE (47M42) 13217E5363 (97403)		EA	2	*	*	*	*	1-2	33
P20	6680-197-4942	BALL, FLOAT (47M47) 13217E5362 (97403)		EA	1	*	*	*	*	1-2	34
		GROUP 04 - TANK AND FRAME ASSEMBLY									
X		TANK AND FRAME ASSEMBLY (49M26) 13217E5353 (97403)		EA	1	*	*	*	*	1-2	1
X20		PLATE, INSTRUCTION (29M93) 13216E2767 (97403)		EA	1	*	*	*	*	1-2	18
X20		PLATE, DATA (49M20) 13217E5366 (97403)		EA	1	*	*	*	*	1-2	19
X20		PLATE, DATA (47M44) 13217E5358 (97403)		EA	1	*	*	*	*	1-2	20
P O	5305-253-5615	SCREW, DRIVE (29930) MS21318-21 (96906)		EA	4	*	*	*	*	1-2	24
X20		PLATE, IDENTIFICATION (49M21) 13217E5357-1 (97403)		EA	1	*	*	*	*	1-2	25
P O		CLAMP, GROUNDING (49M16) 13217E9335-1 (97403)		EA	1	*	*	*	*	1-2	26
P O	5975-878-3791	GROUND ROD ASSEMBLY (49M27) MILR11461 (81349)		EA	1	*	*	*	*	1-2	27
X20		PLATE, DATA (47M43) 13216E2718 (97403)		EA	1	*	*	*	*	1-2	28
X20		PLATE, DATA (29M94) 13216E2766 (97403)		EA	1	*	*	*	*	1-2	35
P O	4730-992-7270	PLUG, PIPE (37982) MS20913-4K (96906)		EA	1	*	*	*	*	1-2	37

Section V. INDEX OF FEDERAL STOCK NUMBERS AND
REFERENCE NUMBERS
(CROSS-REFERENCE TO FIGURE AND ITEM NUMBER)

<i>Stock No.</i>	<i>Fig. No.</i>	<i>Item No.</i>	<i>Stock No.</i>	<i>Fig. No.</i>	<i>Item No.</i>
4330-112-0256	1-2	23	MS27020-11 (96906)	1-2	38
4330-983-0998	1-2	22	MS27024-11 (96906)	1-2	16
4730-079-1362	1-2	38	MS27028-11 (96906)	1-2	39
4730-196-9585	1-2	10	MS27029-11 (96906)	1-2	17
4730-278-4684	1-2	13	MS27030-6 (96906)	1-2	14
4730-915-5127	1-2	17	MS35338-44 (96906)	1-2	9
4730-992-7270	1-2	37	MS51957-85 (96906)	1-2	30
4820-263-9119	1-2	36	MS51957-89 (97403)	1-2	7
4820-407-2581	1-2	5	SB715B7EMILR3065		
5305-071-2088	1-2	30	(81349)	1-2	3
5305-071-2089	1-2	7	WWV54 (81348)	1-2	36
5305-253-5615	1-2	24	13216E2718(97403)	1-2	28
5310-167-0835	1-2	8	13216E2766(97403)	1-2	35
5310-492-2143	1-2	40	13216E2767(97403)	1-2	18
5310-582-5677	1-2	31	13216E2773(97403)	1-2	23
5310-582-5965	1-2	9	13216E2789-5(97403)	1-2	21
5330-235-4716	1-2	33	13216E2798(97403)	1-2	5
5330-612-2414	1-2	14	13217E5353(97403)	1-2	1
5340-823-5318	1-2	39	13217E5354(97403)	1-2	4
5975-878-3791	1-2	27	13217E5356(97403)	1-2	2
6680-197-4941	1-2	29	13217E5357-1 (97403)	1-2	25
6680-197-4942	1-2	34	13217E5358 (97403)	1-2	20
6685-451-3274	1-2	6	13217E5360 (97403)	1-2	29
AN816-5-4D (88044)	1-2	10	13217E5361 (97403)	1-2	32
AN960416L(88044)	1-2	8	13217E5362 (97403)	1-2	33
MIL-R-11461 (81349)	1-2	27	13217E5363 (97403)	1-2	34
MIL-F-52308 (81349)	1-2	22	13217E5365-2 (97403)	1-2	11,12
MS15795-810 (96906)	1-2	31	13217E5366 (97403)	1-2	19
MS20822-5-4D (96906)	1-2	13	13217E9335-1 (97403)	1-2	26
MS20913-4K (96906)	1-2	37	13218E8895-2 (97403)	1-2	6
MS21318-21 (96906)	1-2	24			

ALPHABETICAL INDEX

Subject	Paragraph, Table, Number	Figure, Number	Subject	Paragraph, Table, Number	Figure, Number
A					
Administrative Storage and Demolition	1-4	1-1	Testing, inspection and replacement	4-16	4-8
D					
Description and Data			Movement to a New Work Site		
Demolition	1-4	1-1	Dismantling for movement	4-3	4-2
Description	1-5	1-1	Reinstallation after movement	4-4	4-2
Differences between models	1-6	1-5	O		
Differential pressure indicator	F 4-2	4-7	Operating Instructions		
Identification and tabulated data	1-7	1-5	Operating procedures	2-1	2-1
Schematic flow through system	F 1-1	1-2	Starting	2-2	2-1
G					
General			Stopping	2-3	2-1
Demolition and administrative storage	1-4	1-1	Operation Under Unusual Conditions		
Forms and records	1-2	1-1	Operation under unusual conditions	2-4	2-2
Reporting of errors	1-3	1-1	P		
Scope	1-1	1-1	Preventive Maintenance		
L					
Lubrication Instructions	3-1	3-1	General	3-2	3-1
M					
Maintenance of Filter Separator			Preventive Maintenance Checks and Services		
Element and canister	3-5	3-3	General	3-2,4-8	3-1,4-3
Maintenance of Tank & Frame			Preventive maintenance checks and services	3-3,4-9	3-1,4-3
Assembly			R		
General	4-17	4-8	Repair Parts, Special Tools, and Equipment		
Tank & frame assembly	4-18	4-8	Maintenance repair parts	4-7	4-3
Maintenance of Valves, Lines and Fittings			Special tools and equipment	4-6	4-3
General	4-11	4-5	Tools and equipment	4-5	4-3
Water drain valve	4-12	4-5	S		
Maintenance of Water Level			Service Upon Receipt of Material		
Sight Gage and Differential Pressure Indicator			Inspecting and servicing the equipment	4-1	4-1
Differential pressure indicator	4-15	4-6	Installation	4-2	4-1
Differential pressure indicator assembly, exploded view	F 4-2	4-7	Liquid fuel filter separator front and rear view	F1-2	1-3
General	4-13	4-5	Typical installation	F4-1	4-2
Sight gage	4-14	4-6	T		
T					
Troubleshooting			General	3-4,4-10	3-3,4-5
General	3-4,4-10	3-3,4-5	Troubleshooting chart	T3-2	3-3

By Order of the Secretary of the Army:

CREIGHTON W. ABRAMS
General, United States Army
Chief of Staff

Official:

VERNE L. BOWERS
Major General, United States Army
The Adjutant General

Distribution:

To be distributed in accordance with DA Form 12-25A, (qty rqr block no. 154)
Organizational maintenance requirements for Petroleum Distribution.

☆ U. S. Government Printing Office: 1987 - 201-421 (71041)

PIN: 005928-007